

Scissor Type Top Loading Arm C32RF, H32F

FEATURES AND BENEFITS

The most popular OPW top loading arm used in many applications worldwide.

This versatile arm is designed specifically for top-loading installations where a variable operating range is required. The secondary arm rotates 360 degrees in the horizontal plane providing a spotting allowance of up to twice its length.

Commonly used to handle high flow rates and withstand rough usage in tank-truck loading applications. The scissor type arm is also a good choice for railcar loading applications where cars are frequently mis-spotted.



- **Ideal** for applications where variable spotting of the vehicle is common
- **Easy to handle**, smooth operation
- **All flanged construction** for ease of maintenance (available in 3" and above)
- **Swivels** equipped with grease nipple
- **Durable** construction
- **C32RF** with inboard loading valve and remote control handle, H32F without valve
- **Available in** 2" / dn50, 3" / dn80 or 4" / dn100 with ASA 150lbs RF or DIN PN10/16 inlet flange
- **Inverted** inlet swivel orientation, model C33RF or H33F, to assist self draining capability available
- **Adaptable** to tight-fill or closed-system loading with optionally supplied swivels and couplers
- **Alternative materials** of construction Carbon Steel or 316/316L Stainless Steel
- **Wide range** of swivel seal material available
- **Pre-balanced** at the factory to minimise installation and commissioning time

CERTIFICATES



NEN-EN-ISO 9001:2000



PED 97/23/EC

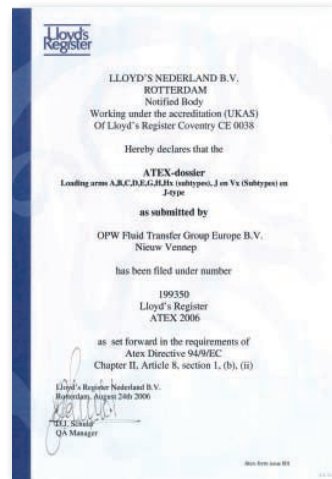

ATEX 94/9/EC

PRODUCT SPECIFICATION

Materials of construction

Inlet swivel	Ductile Iron
Intermediate swivel	Aluminium
Drop tube swivel	Aluminium
Swivel seals	Viton® GFLT
Primary arm	Aluminium
Secondary arm	Aluminium
Drop tube	Aluminium

DIMENSIONS

Size	Dimensions (in mm)			
	D	G	M	R
2" / dn50	2200	1500	700	381
2" / dn50	2800	1750	900	381
3" / dn80	2200	1500	700	406
3" / dn80	2800	1750	900	426
4" / dn100	2200	1500	700	451
4" / dn100	2800	1750	900	451

Other dimensions available on request

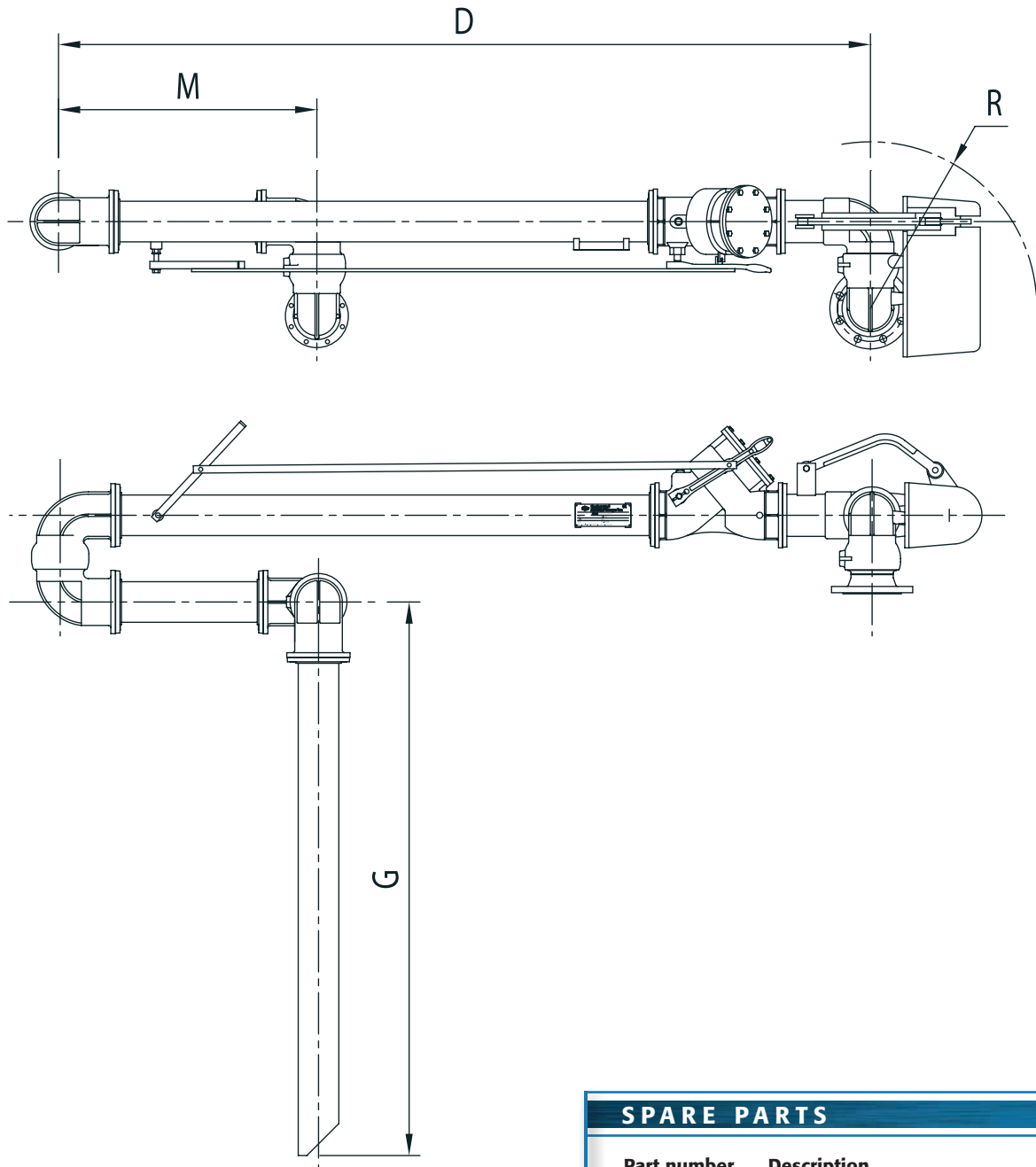

SPARE PARTS

Part number	Description
3002K-20-VG	2"/dn50 swivel seal replacement kit, Viton® GFLT
3002K-30-VG	3"/dn80 swivel seal replacement kit, Viton® GFLT
3002K-40-VG	4"/dn100 swivel seal replacement kit, Viton® GFLT
6402RK-0202	2"/dn50 loading valve repair kit, Viton®
6402RK-0302	3"/dn80 loading valve repair kit, Viton®
6402RK-0402	4"/dn100 loading valve repair kit, Viton®

- **Closes automatically** when lever is released
- **Adjustable closing ratio** prevents line shock, ensures smooth valve closure
- **Integrated** TTMA flanges
- **Straight** or angle design
- **Built in** Vacuum Breaker Valve
- **Viton®** seal as standard, optional Buna; LT Buna.

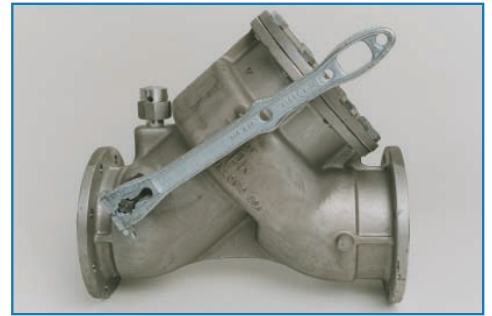

ACCESSORIES

Article number	Description
466-AL30	Drip pan, for 3" /dn80 arm
466-AL40	Drip pan, for 4" /dn100 arm
464RP-AL30	T-deflector, for 3" /dn80 arm
464RP-AL40	T-deflector, for 4" /dn100 arm
788L-0040	Lock down device, right hand configuration
788LLH-0045	Lock down device, left hand configuration

Optional available accessories include: Level detection; Position detection; Working position locking device, Parking lock, Automated or manual ball valve, Telescopic Drop tube, Stand Post and many more, please consult factory for information and availability.

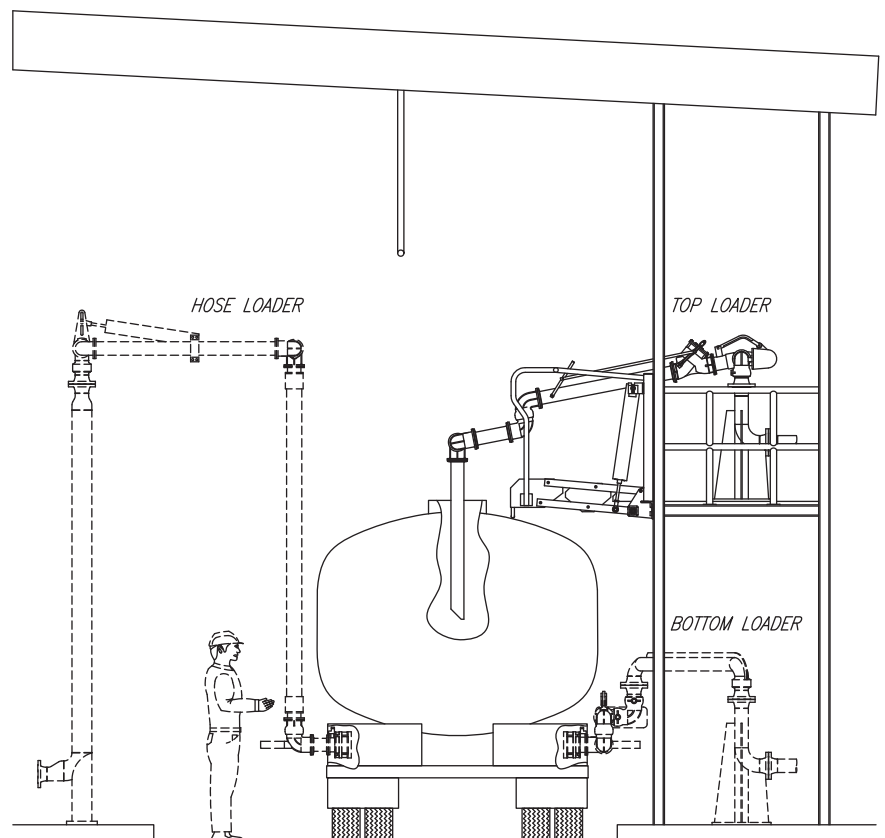
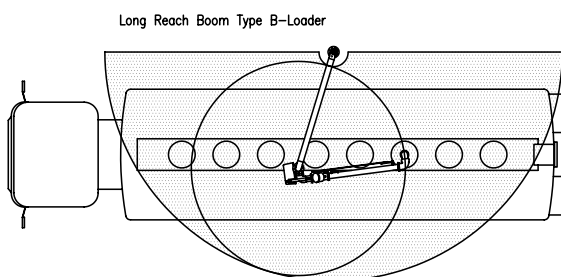
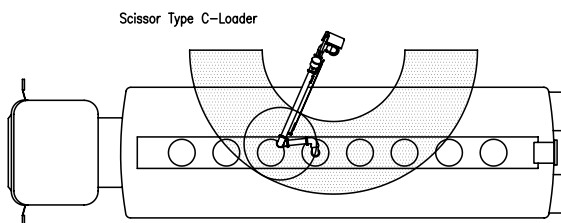
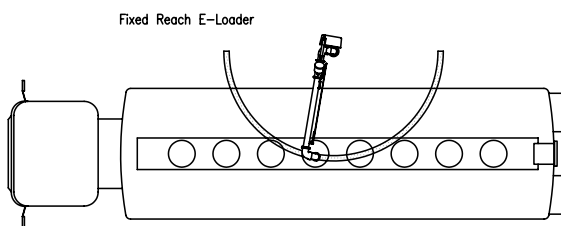

OPW Fluid Transfer Group: One Company, Five Brands



Dedicated engineered and patented solutions for pipe, tube and hose connections used for extreme applications high/low temperature & pressure and nuclear.

Examples: RapidLOK[™] for flange replacement; save vents and drains; locking quick connect; product recovery systems; cryogenic couplings; autoclave check valves ...

www.hiltap.com



Mechanical and electronic components and systems for the safe loading, transportation and offloading of hazardous fluids on road tankers. Examples: flat bottom API's; bottom valves; vapour recover valves; overflow prevention system; sealed parcel delivery system; onboard monitoring system; crossover prevention system ...

www.civacon.com



Mechanical and electronic components and systems for the safe storage, transfer and loading of hazardous fluids at chemical plants, refineries and terminals.

Examples: loading arms for fuels, chemicals, bitumen; rack monitoring system; quick disconnects (kamlok[®], autolok[™]); dry disconnects (epsilon[™], drylok[™], kamvalok[®]); floating suction assemblies ...

www.opw-es.com



Components and systems for the safe loading, transportation and offloading of hazardous fluids and dry bulk on pressure & non-pressure railroad tank cars and dry bulk road tankers.

Examples: pressure & vacuum relief valves; needle valves; top transfer valves; valve actuator systems; overflow prevention systems ...

www.midlandmfg.net



Components for pneumatic tank trailers, rail cars, chemical and pharmaceutical plants, and any application requiring the processing, movement and storage of dry bulk or liquid materials.

Example: butterfly valves; ball valves; sample systems; actuators; aeration systems; swing check valves ...

www.suresealinc.com



From the European Head office near Amsterdam The Netherlands, these 5 OPW Fluid Transfer Group brands are supported. In addition Loading Arms, Tank Truck equipment and its related accessories are designed and manufactured here to serve the OPW FTG Europe BV territory.

www.opw-ftg.nl