



Safety cage independent

Safety systems

The independent safety cage is available in a wide variety of designs.

This can be installed at the loading bay roof, or at separate support columns at the side of the loading bay.

The independent safety cage aims to cover larger working areas on top of a truck to ensure safe and easy working under all circumstances.

Features

- Carbon steel frame work for the rigidity, combined with aluminium parts to reduce the overall weight
- Hot dip galvanizing according to the latest ISO 1461 standard
- Hand-, knee-, and foot rail
- Pneumatic/hydraulic operation
- Hinged or vertical movement
- Suitable for hazardous areas
- Working area coverage up to 12m width

Options

- Construction in aluminium
- Additional foot board
- Side opening to allow for easy access of the loading arm
- Reverse V-, U- shape of the foot rail to follow the lines of the truck or rail tanker
- Can be painted in any RAL color available
- Vertical fall arrest door to reduce any opening between the foot rail and truck or rail tanker
- Movable door inside the safety cage to adapt the working area to each truck

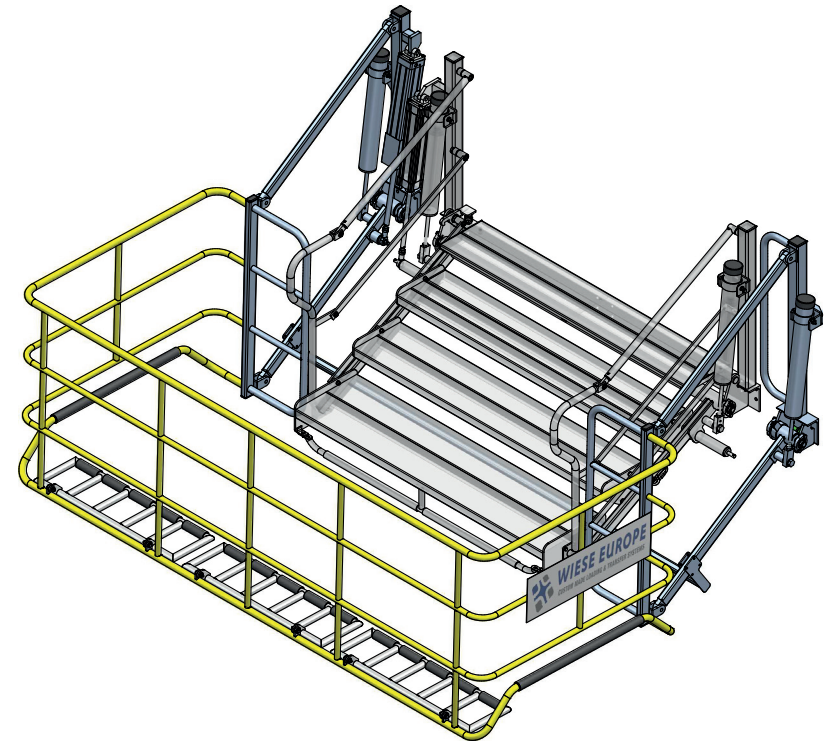

Wiese Europe bvba

Smederijstraat 16
2960 Brecht
Belgium

+32 3 633 16 10
info@wiese-europe.com
www.wiese-europe.com

