

# RM140 Overfill Protection Rack Monitor

Overfill Protection & Grounding monitor for loading, road, rail, petro-chemical and food applications.

Built to function with all probes designed to the API code, API RP 1004 and the EU Standard EN13922, the Liquip RM140 Series is the world's most flexible and competitive monitor.

The RM140 provides a fail-safe, state-of-the-art Overfill Protection & Grounding monitoring system that is compatible with all commonly used Overfill Protection and Grounding systems.

## Key Features

- Automatic sensing of two-wire/thermistor & five-wire overfill systems.
- Supports up to 8 two-wire/thermistor probes & up to 12 five-wire probes.
- High Output display visible in direct sunlight.
- Coded wireless By-Pass key for secure & reliable operation.
- Self test at start-up / Continuous self-monitoring.
- Separate Grounding & Overfill control outputs.
- Compact & functional design is easy to install.
- One model of electronics for the whole world.
- RM100 is directly compatible with PD100 Probe Doctor as a "plug in replacement"



## Models

- RM140 - RM100 Electronics in a 100mm (4") deep enclosure.

## Certification & Compliance

- Type of Protection: Explosion-proof enclosure for Group II, Zone 1, Ex d [ia]
- IECEx Certificate: IECEx TSA 05.0049X  
Marking: Ex db [ia Ga] IIB T6 Gb  
(-20°C ≤ Tamb ≤ 70°C) IP66
- ATEX Certificate: DEMKO 06 ATEX 140833X  
Marking: **CE** 0518  II 2 (1) G  
Ex db [ia Ga] IIB T6 Gb  
(-20°C ≤ Tamb ≤ 70°C) IP66
- EU Directives: 2014/34/EU (ATEX)  
2014/30/EU (EMC)  
2002/95/EC (RoHS)  
Compatible with EN13922
- FM Approval: FM Approved for US and Canada.  
Marking: Explosionproof with I.S. Outputs  
Intrinsically Safe Sécurité Intrinsèque Exia  
Class I, Division 1, Group C & D, T6  
Ta = -25°C to +60°C



# Electrical

Power:	240V Operation	110V Operation
Minimum Input Voltage:	185 Vac	85 Vac
Maximum Input Voltage:	275 Vac	135 Vac
In-rush Current:	2.2 A	2.3 A
Maximum Current:	400 mA	400 mA
Normal Power Consumption:	8.6W (No probe) 20W (8x 2-wires probes)	8.6W (No probe) 20W (8x 2-wires probes)
Mains Power Fuse Rating:	250V, 400mA anti-surge 1500A Breaking Capacity	250V 400mA anti-surge 1500A Breaking Capacity

## INTRINSICALLY SAFE SIGNALS

- ◆ Nominal Voltage: 10.5V, 13.02V Max
- ◆ Nominal Current: 116mA, 121mA Max
- ◆ Relay Outputs: Overfill Monitoring Relay
- ◆ Relay Contacts: Common, Normally Open, Normally Closed
- ◆ Maximum Contact Voltage: 250 Vac
- ◆ Maximum Contact Load: 5 A (resistive), 2.5A (inductive)
- ◆ Relay Fuse Rating: 250V @ 5A anti-surge

## MECHANICAL

- ◆ Width: 324mm (12.8")
- ◆ Height: 340mm (13.4")
- ◆ Depth: 170mm (6.7") – RM140
- ◆ Weight: 16.5 kg
- ◆ Material: Aluminium housing base & cover  
Laminated glass window

## SPARES & ACCESSORIES

- ◆ 6987 Fuse 400mA, 250Vac anti-surge, 1500A Breaking Capacity
- ◆ 5542 Fuse 5A @ 250Vac anti-surge
- ◆ 6985 RM100 Safety Ground Harness
- ◆ RM100-3 RM100 Aluminium Safety Barrier
- ◆ RM100-4 RM100 Polycarbonate Terminal Cover
- ◆ RM100-5K RM100 PCB Assembly Complete Kit (RM100-5 + 6959 Display)
- ◆ GP103 3 Bayonet Gantry Plug with Cable
- ◆ GP104 4 Bayonet Gantry Plug with Cable
- ◆ GP204U 4 Bayonet Gantry Plug screened Cable, Complies with EN13922
- ◆ TPA3 3 Bayonet Gantry Plug Parking Adaptor
- ◆ TPA4 4 Bayonet Gantry Plug Parking Adaptor
- ◆ JB100 Junction Box with 2 threaded Gland entries
- ◆ JB103 Junction Box with 3 Threaded gland Entries
- ◆ HTA204 Two-wire Optical Hand Tester
- ◆ HTA503 Five-wire Optical Hand Tester
- ◆ EAC201 Earth Clamp with Straight Cable
- ◆ EAC202 Earth Clamp with Coiled Cable
- ◆ LDP202 Two-wire Level Detection Probe
- ◆ LDP205 Five-wire Level Detection Probe
- ◆ 6983 RM140 Bypass Fob



# LIQUIP

## RM100 SERIES RACK MONITOR

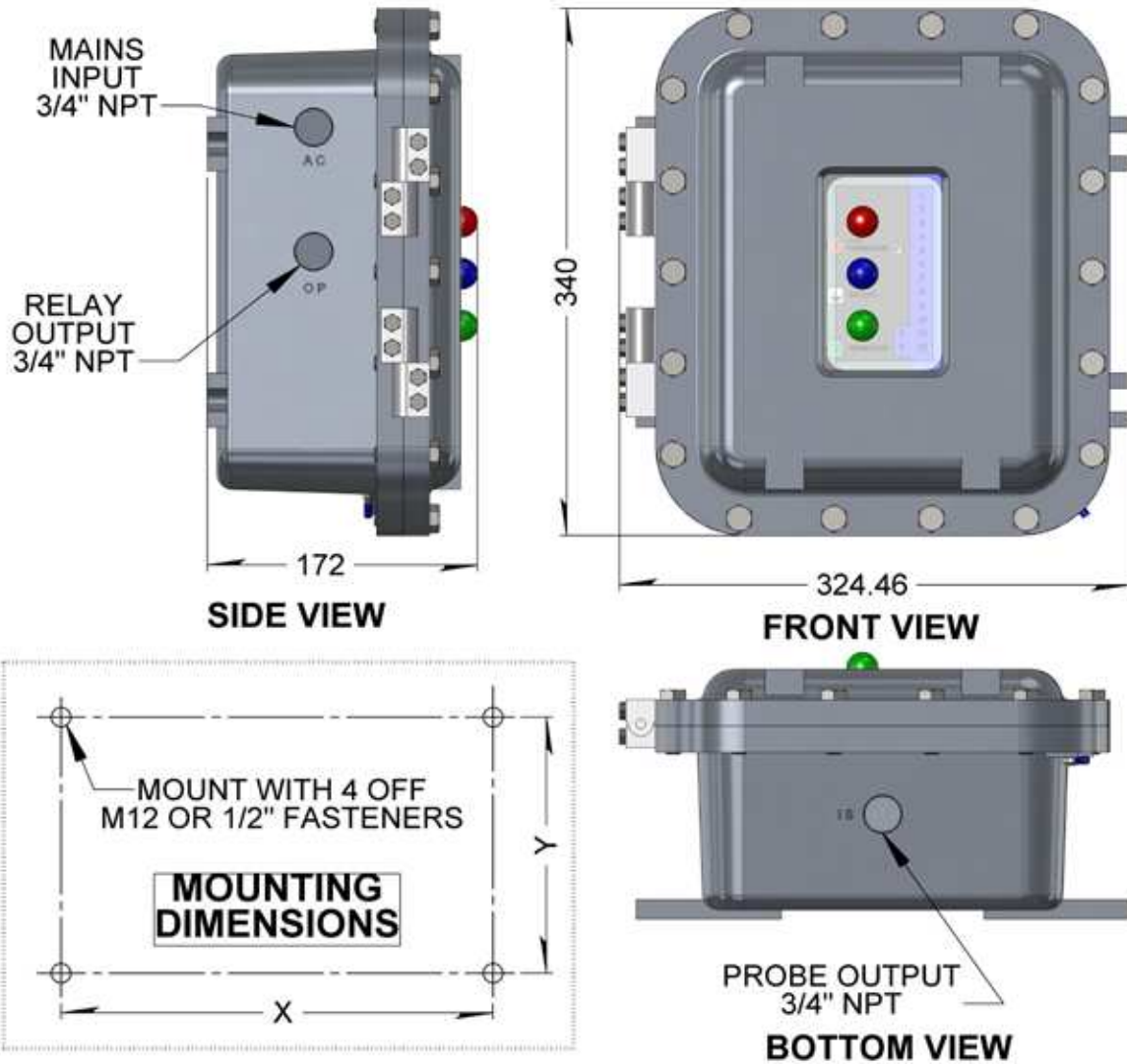

Model	X	Y	Z
RM140	285mm (11.2")	165mm (6.5")	170mm (6.7")
RM160	275mm (10.8")	165mm (6.5")	220mm (8.7")

X1051205

Issue: A

METERS - VALVES - VENTS - MANHOLES - PUMPS - HOSEREELS - OVERFILL PROTECTION - LOADING ARMS - ELECTRONIC DIPSTICKS



LIQUIP INTERNATIONAL PTY LTD  
 13 Hume Road  
 Smithfield, 2164  
 Sydney NSW Australia  
 Phone: +612 9725 9000  
 Fax: +612 9725 1252

DISTRIBUTORS  
 See inside front cover  
 for Liquip branches  
 and Distributors

[www.liquip.com](http://www.liquip.com)