



LYNX

LYNX Series Bottom Loading Coupler

Installation, Operation & Maintenance
(IOM) Manual

Contents

LYNX Series Datasheet	3
LYNX Series Drawing	4
LYNX Series Parts List	5
LYNX Series Exploded View	6
Testing For Excessive Wear	7
Suggested Maintenance Schedule	7
Replace Product Seal (In-Situ)	8
Replace Outer O-ring (In-Situ)	9
Replace Bush and O-ring Assembly (On Work Bench)	10
Disassemble and Reassemble Procedure – Disassemble (On Work Bench)	12
Disassemble and Reassemble Procedure – Reassemble (Continued)	14
Troubleshooting	17
Spare Parts	18

Features & Benefits

The LYNX Series combines all of the best features of API couplers in one device to provide a superior and effortless bottom loading experience. Featuring stainless-steel components and coming in at 19 lbs. (8.6kg), the LYNX Series coupler is impressive by any measure.

From the moment you use LYNX, you will see the extraordinary attention to detail and superior quality that enables LYNX to provide outstanding performance, advanced safety, ease of service and long life.



LYNX

Selection Guide

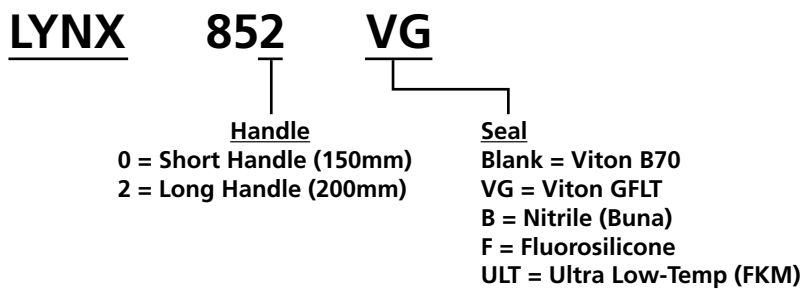

Example: LYNX 852 VG = Long Handle with Viton GFLT Seal

Custom Options: Chemical Trim (LYNX 852 C)

Note: Please see page 18 for other seal options and for a list of common spare parts.

Specifications

Part Number	Description
Handle Length	Short 5.9" (150 mm) or Long 7.8" (200 mm).
Seals	Viton B, Viton GFLT, Nitrile/Buna, Fluorosilicone, FFKM
Max Working Pressure	80 psi (5.5 bar) (550 kPa)
Product Test Pressure	119 psi (8.2 bar) (820 kPa)
Design Pressure	363 psi (25 bar) (2500 kPa)
Max Surge Pressure	493 psi (34 bar) (3400 kPa)
Operating Temperature	Viton B70: 0°F to 200°F (-15°C to +90°C); Viton GFLT: -20°F to +200°F (-28°C to +90°C); Nitrile/Buna: -40°F to 212°F (-40°C to 100°C); Fluorosilicone: -49°F to 350°F (-45°C to 177°C); FFKM: 23°F to 140°F (-5°C to 60°C); FKM (Ultra Low-Temp): -40°F to 200°F (-40°C to 90°C)
Design Standard	API RP 1004 8th EDITION 2003 - Bottom Loading and Vapor Recovery; AS5602-2009.
Dismantling	Removal of one U-pin enables the shaft assembly and main poppet to be withdrawn
Mounting	<ul style="list-style-type: none"> By industry standard 100 mm (4") TTMA Flange. 8 holes Ø11 mm on 149 mm PCD, 168 mm outside diameter (Ø7/16" on 5.8" PCD, 6.6" OD). Use spring washers when mounting coupler as per common industry practice.
Adjustment or Service	Refer to Maintenance Instructions document.
Weight	19 lbs. (8.6 kg.)

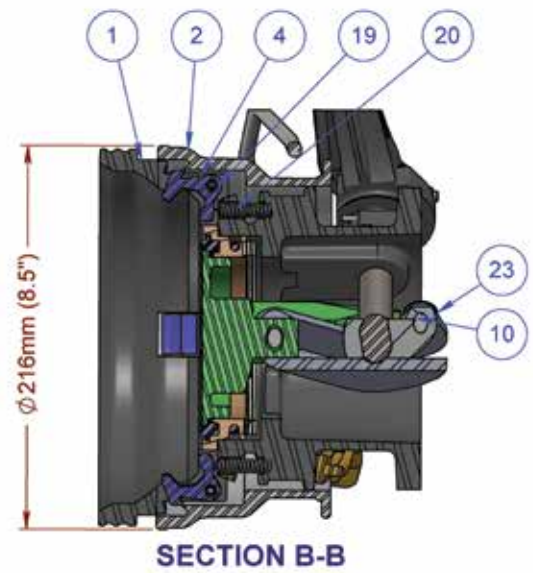
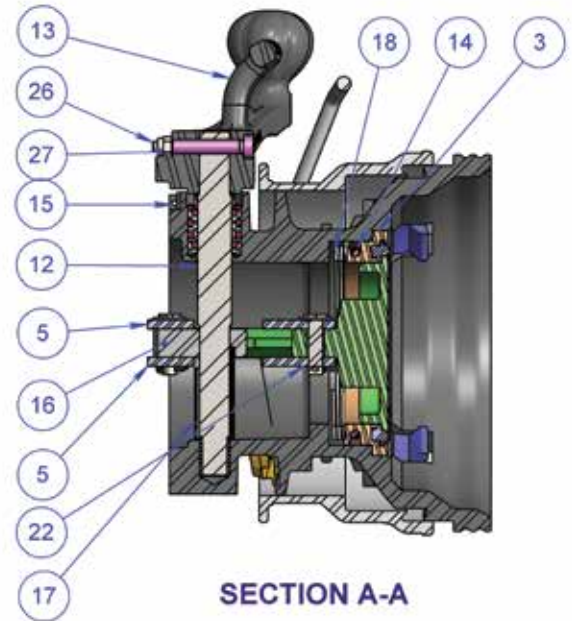
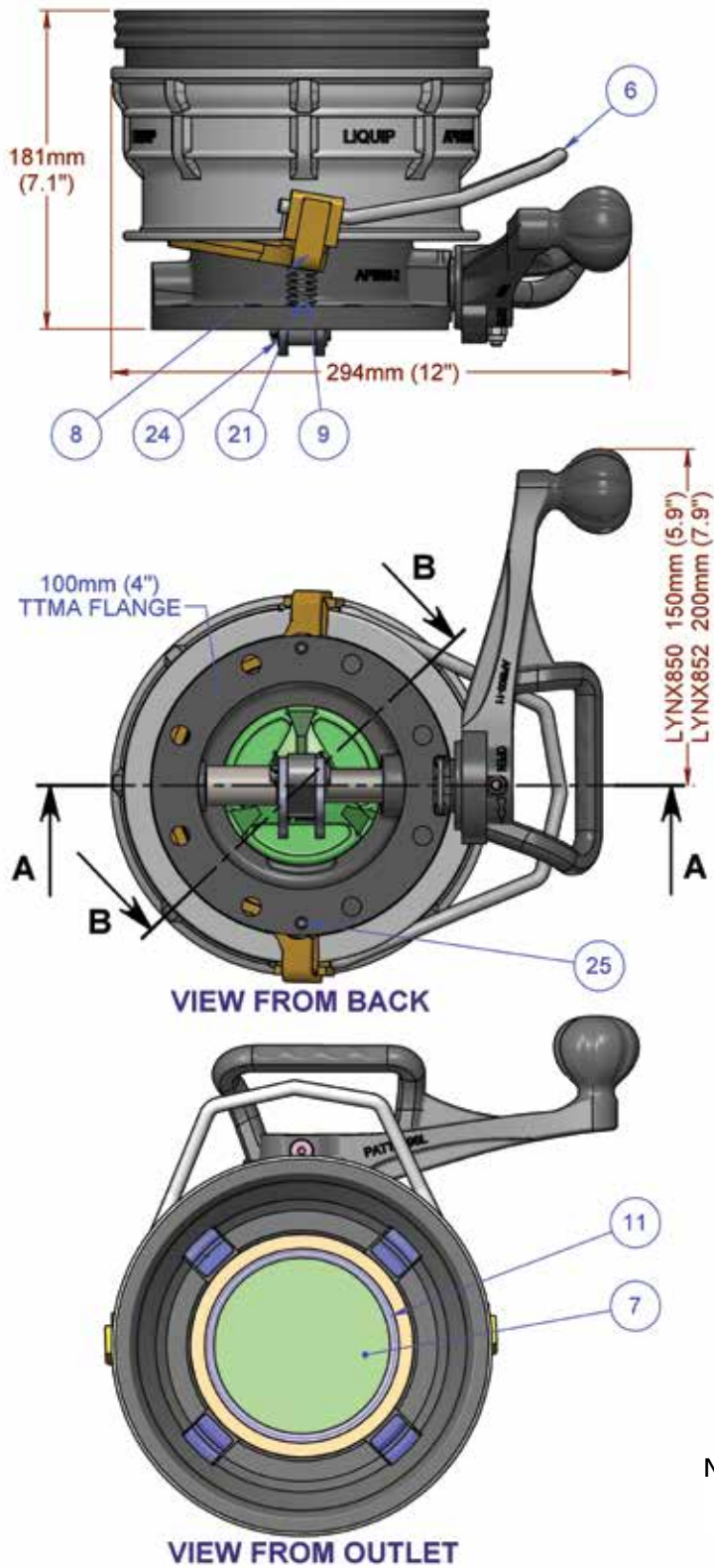

NOTE: LYNX852 Long Handle Shown

LYNX Series Bottom Loading Coupler

Item No.	Part Number	Description	LYNX850	LYNX852	LYNX850VG	LYNX852VG	Material
1	API800-2	Body API800 Series Coupler	1	1	1	1	Aluminum
2	API800-3	Outer Body (Collar)	1	1	1	1	Stainless Steel
3	API800-4	Poppet Adaptor Ring	1	1	1	1	Aluminum
4	API725-4	Latch Collar Interlock	4	4	4	4	Stainless Steel
5	API800-6	Camplate for API Couplers	2	2	2	2	Steel Phosphate
6	API555-6	Handle - Outer Body	1	1	1	1	Stainless Steel
7	API800-9	Poppet 4"	1	1	1	1	Aluminum
8	API555-10	Lever Outer Body	1	1	1	1	Aluminum
9	API800-13	Pin - Spring Return	2	2	2	2	Stainless Steel
10	API800-12	Pin Clevis	2	2	2	2	Steel Phosphate
11	API800-1	Seal Product	1	1	-	-	Viton B
	API800-1VG	Seal Product	-	-	1	1	Viton GFLT
12	API50-5A	Shaft and Bush Assembly	1	1	-	-	Steel, Viton A & Acetal
	API850-5AVG	Shaft and Bush Assembly	-	-	1	1	Steel, Viton GFLT & Acetal
13	API800-11	Long Handle	-	1	-	1	Aluminum
	API800-15	Short Handle	1	-	1	-	Aluminum
14	0203	O-ring	1	1	-	-	Viton B70
	0203VG	O-ring	-	-	1	1	Viton GFLT
15	API800-23	U-pin	1	1	1	1	Spring Steel
16	API800-27	Eccentric Cam with Sleeve Cutouts	1	1	1	1	Stainless Steel
17	API1800-28	Spacer Sleeve	1	1	1	1	Stainless Steel
18	6182	Spirawave Spring	1	1	1	1	Spring Steel
19	0927	Spring (Sellok) Pin	4	4	4	4	Z/P Steel
20	6171	Spring Compression	4	4	4	4	Stainless Steel
21	4497	Spring - Return	2	2	2	2	Spring Steel
22	5351	Washer Flat Thin	2	2	2	2	Stainless Steel
23	0101	Washer Flat	2	2	2	2	Z/P Steel
24	0762	Split Cotter Pin	4	4	4	4	Stainless Steel
25	3227	Grub Screw Met	2	2	2	2	Black Steel
26	55091	Cap Screw Shoulder Metric	1	1	1	1	Steel Phosphate
27	4399	Nut Nyloc	1	1	1	1	Z/P Steel

Note: For a list of common spare parts, refer to page 18.

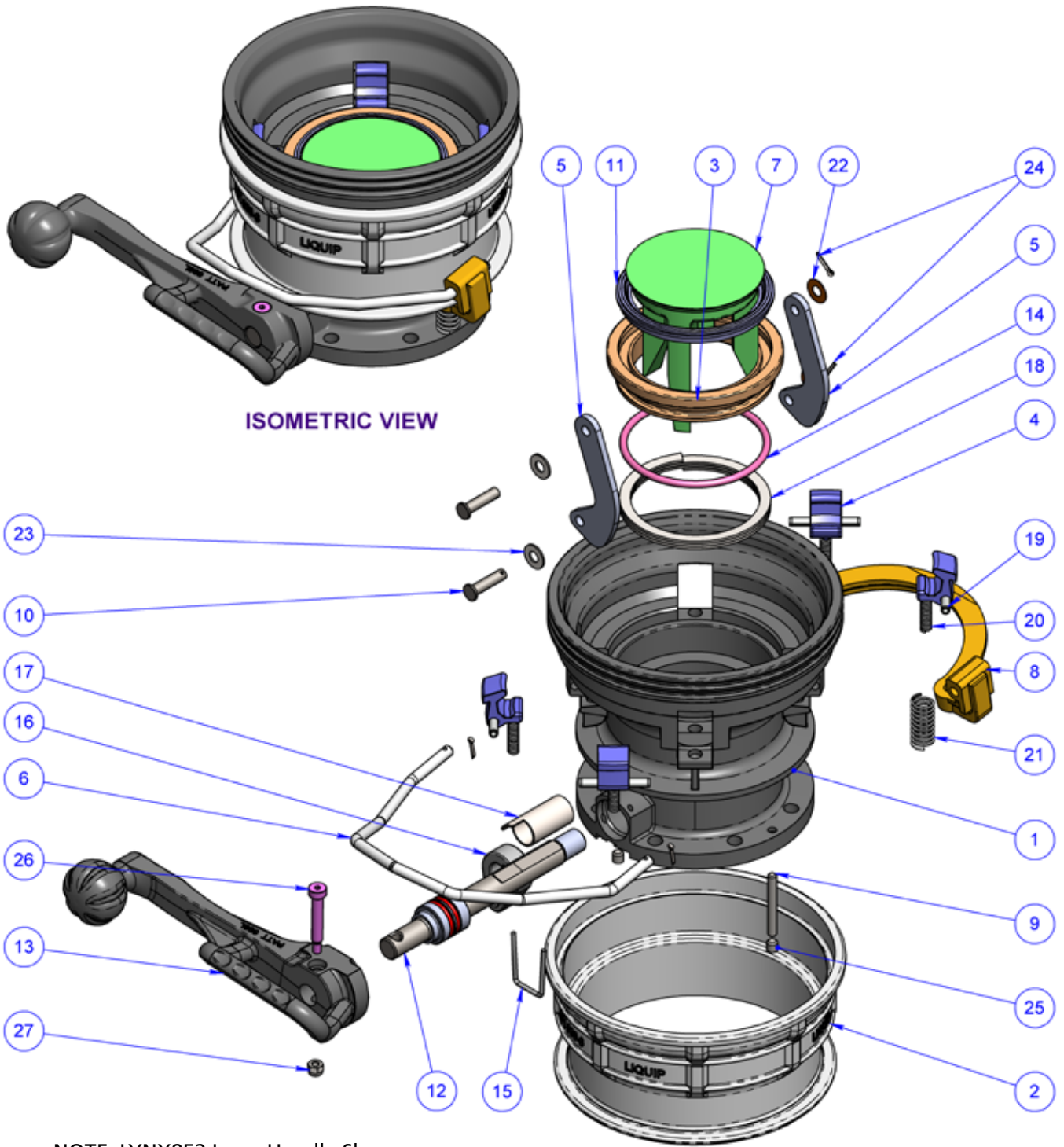

ISOMETRIC VIEW

ISOMETRIC EXPLODED VIEW

NOTE: LYNX852 Long Handle Shown

Attention:

The Steps Outlined In This Document Must Be Performed By Authorized Personnel Only. For Further Explanation, Please Contact Your OPW Engineered Systems representative.

1. Testing for Excessive Wear

Option 1: Connect an API-LI to the LYNX Series coupler. Please consult OPW Engineered Systems for more info on the API-LI.

Option 2: Connect the coupler to a new API vehicle adaptor. With the vehicle adaptor clamped securely in a vice, try to rock the coupling in relation to the vehicle adaptor. Be sure to rock the coupler about the axis which it would normally receive the most wear and tear. If there is any more than 5 mm lateral movement at the back end of the coupler, it is worn out and unserviceable.

2. Suggested Maintenance Schedule

Recommended Service Schedule for LYNX Series couplers.
Because loading gantries vary in usage, the following schedule is calculated on the number of connections.

1. Determine the Loading Gantry Category

Note: All chemical couplers should be treated and maintained as per the HIGH USE schedule.

- a. LOW USE: 1 to 10 Connections per day.
- b. MEDIUM USE: 11 to 20 Connections per day.
- c. HIGH USE: 21 to 50 Connections per day.

Choose a category that best suits your loading gantry.

2. Service Number

a. SN 1

- i. Visually inspect the product seal for damage, replace if required.
- ii. Visually inspect latches for dirt build-up and clean if required.
- iii. Inspect handle interlock for damage, report and locate cause if evident.
- iv. Visually inspect for leaks on all sealing areas while the coupler is on the loading arm.

b. SN 2

As SN 1 with the addition of:

- i. Check the operation of the self-latching mechanism for smooth and free operation.
- ii. Visually inspect the latches for excessive wear.
- iii. Visually inspect poppet adaptor ring for damage.
- iv. Visually inspect the body adjacent to the poppet adaptor ring for mushrooming and/or burrs.
- v. Visually inspect the poppet face for damage.

c. SN 3

As SN 1 and SN 2 with the addition of:

- i. Strip and remove shaft and bush assembly and replace O-ring and bush assembly.
- ii. Check the hinge casting and wire handle are in good condition and do not show significant signs of wear. Check springs are not broken.
- iii. Visually inspect the wave spring for damage, replace if required.
- iv. Visually inspect the latches for excessive wear when stripped. Inspect the roll pin axles to make sure they are tight and not worn. Replace if required.
- v. Replace all product seals and outer O-ring.
- vi. Visually inspect the sealing surface for the poppet adaptor ring, if any wear or damage is shown in this area, replace the body.
- vii. Check valve mouth for excessive wear or damage and replace body if required.

Operating Period	Low Use	Medium Use	High Use
3 MONTHS	SN 1	SN 1	SN 1
6 MONTHS	SN 1	SN 1	SN 2
9 MONTHS	SN 1	SN 2	SN 1
1 YEAR	SN 2	SN 1	SN 3
1 YEAR & 3 MONTHS	SN 1	SN 1	SN 1
1 YEAR & 6 MONTHS	SN 1	SN 3	SN 2
1 YEAR & 9 MONTHS	SN 1	SN 1	SN 1
2 YEARS	SN 3	SN 2	SN 3

3. Replace Product Seal (API800-1/API800-1VG/API800-1K/API800-1NBR) (IN-SITU)



NOTE: Photos are provided for key steps

◆ = Care must be taken to ensure the quality of the unit.

1. Isolate loading arm to prevent product flow. Drain off fluid in the loading arm and ensure the LYNX is clean and dry.
2. Squeeze the handle (API555-6) and push all four latches in at once. While holding the latches in, slowly release the handle to allow the collar to slide forward.
3. Turn the operating handle (API800-11 or API800-15) to open the poppet (API800-9).
4. Push the poppet adaptor ring (API800-4) back and remove the product seal using a suitable tool ensuring you don't damage the poppet adaptor ring.

◆ **NOTE:** Do not damage the poppet adaptor ring when removing the product seal.

5. Clean the product seal groove and poppet adaptor ring using a clean cloth.

6. Inspect the poppet's tapered sealing face ensuring it is clean and free from damage. If dirty, remove grease and debris with a clean cloth, and if damaged, replace the poppet (as per Section 6 on page 12).

◆ **NOTE:** Ensure you inspect the poppet seal face for damage and replace if required.

7. Check and inspect wear on poppet legs. If poppet legs are worn, replace the poppet.

◆ **NOTE:** Ensure you inspect poppet legs for damage and replace if required.

8. Push the new product seal into the product seal groove using your thumbs, ensuring the seal is fitted correctly under the groove.

◆ **NOTE:** When installing the product seal, loosely press in 4 places equally around the seal before pushing the seal securely home to avoid uneven compressing of the seal. Ensure the seal's outside edge is in the groove all around.

9. Check that the product seal is fitted correctly by rubbing your fingers over it. It should feel free from lumps.

◆ **NOTE:** If lumps are felt, remove the product seal and refit. It is important that the product seal is fitted correctly.

10. If you want to replace the outer O-ring, follow steps 4 – 7 of Section 4 on page 9 and then continue this procedure.

11. Close the coupler operating handle and then pull back the latch release handle allowing the collar to retract and click into place.

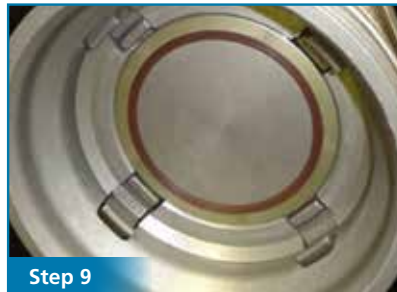

4. Replace Outer O-ring (0203/0203VG/0203K/0203B) (IN-SITU)



NOTE: Photos are provided for key steps

◆ = Care must be taken to ensure the quality of the unit.

1. Isolate loading arm to prevent product flow. Drain off fluid in the loading arm and ensure LYNX is clean and dry.
2. Squeeze the handle (API555-6) and push all four latches in at once. While holding the latches in, slowly release the handle to allow the collar to slide forward.
3. Turn the operating handle (API800-11 or API800-15) to open the poppet (API800-9).
4. Pull the poppet adaptor ring (API800-4) forward.
5. Remove the outer O-ring (0203 or 0203VG) without damaging the poppet adaptor ring.
- ◆ **NOTE:** Do not damage the poppet adaptor ring when removing outer O-ring.
6. Clean the outer O-ring poppet groove and body mating surface using a clean cloth.
7. Grease the new outer O-ring using solvent-resistant grease and install the O-ring onto the poppet adaptor ring.
- ◆ **NOTE:** During insertion, minimize O-ring twist and do not overstretch or damage the O-ring. Do not roll the O-ring into place, as this will shorten the life of the O-ring.
8. Close the coupler operating handle and pull back the latch release handle allowing the collar to retract and click into place.



5. Replace Bush and O-ring Assembly (On Work Bench)



NOTICE

NOTE: Photos are provided for key steps

◆ = Care must be taken to ensure the quality of the unit.

1. With the coupler removed from the arm, squeeze the handle (API555-6) and push in all four latches in at once. While holding the latches in, slowly release the handle to allow the collar to slide forward.
2. Turn the operating handle (API800-11 or API800-15) to open the poppet (API800-9).
3. Remove the cap screw (55091) and nyloc nut (4399) using an Allen key and remove the operating handle.
4. Remove U-pin (API800-23) from above the bush assembly using a pair of pliers.



WARNING

WARNING: Wear safety glasses and remove U-pin with caution as it might spring out when removed.

5. Extract the bush and O-ring assembly. Tip: Jiggle out the shaft to help extract the bush and O-ring assembly.
6. Remove the bush and O-ring assembly. If the washer comes out, clean it with a clean cloth for refitting as per step 8.
7. Clean the shaft and the bore of grease and debris using a clean cloth.
8. Install the new washer if it came out during step 6. If it did not come out, simply grease the new bush and O-ring assembly well using solvent resistant grease and install the new bush and O-ring assembly, ensuring it clears the U-pin groove.

◆ **NOTE:** Use your thumbs to push the bush and O-ring assembly into place until it is seated into position and ensure the bore is clean and free from debris.

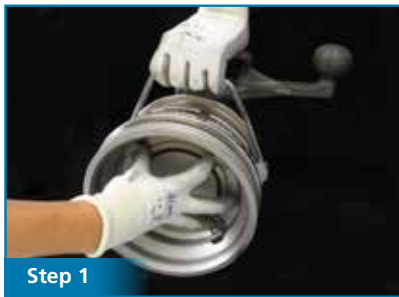

Step 1



Step 2



Step 3



Step 4



Step 5



Step 6



Step 8

9. Install the U-pin and ensure it is secure.



WARNING: Wear safety glasses and install U-pin with caution as it might spring out during insertion.

10. Refit the operating handle as per the orientation shown and refit the cap screw & nyloc nut (4399), ensuring the handle is secured in place by tightening the cap screw/nyloc nut.

- ◆ **NOTE:** 1. Ensure a new nyloc nut is used each time. Do not re-use old nyloc nut.
2. When refitting the handle bolt, the recommended torque is 3-4 N m (this is the torque required to screw through the nyloc nut, but excessive force may damage or strip the nut threads).

11. Close the coupler operating handle and pull back the latch release handle allowing the collar to retract and click into place.



6.1.1 Disassemble And Reassemble Procedure (On Work Bench)



NOTICE

NOTE: Photos are provided for key steps

◆ = Care must be taken to ensure the quality of the unit.

Disassemble

1. With the coupler removed from the arm, squeeze the handle (API555-6) and push in all four latches in at once. While holding the latches in, slowly release the handle to allow the collar to slide forward.
2. Turn the operating handle (API800-11 or API800-15) to open the poppet (API800-9).
3. Remove the cap screw (55091) and nyloc nut (4399) using an Allen key and remove the operating handle.
4. Remove U-pin (API800-23) from above the bush assembly using a pair of pliers.



WARNING

WARNING: Wear safety glasses and remove U-pin with caution as it might spring out when removed.

5. Hold the eccentric cam (API800-27) so it remains in position without tilting and remove the operating handle and shaft assembly by pulling the handle away from the coupler body.
6. Remove the sleeve from the bottom groove where the shaft sits.
7. Lift the coupler body. The poppet (API800-9) and wave spring (6182) will come out. (Put these aside)
8. Remove the grub screws (3227) using an Allen key.



Step 1



Step 2



Step 3



Step 4



Step 5



Step 6



Step 7

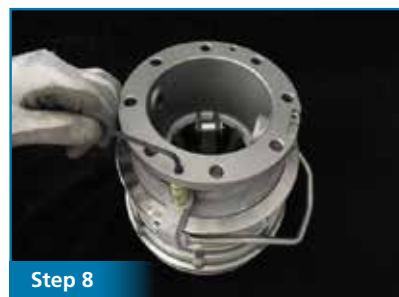

Step 8

9. Turn the unit so the flange faces down and the pins (API800-13) should slide out.
10. Turn the unit so the flange faces up.
11. Remove the springs (4497). If they are damaged, replace them as required.



WARNING: Wear safety glasses and remove U-pin with caution as it might spring out when removed.

12. Remove split pin (0762) from the latch release handle (API555-6) and lever (API555-10).
13. Pull the latch release handle.
14. Lift and slide out the lever.
15. Lift the collar off the body (API800-2).
16. Inspect the collar for wear. If wear is evident, contact your local OPW Engineered Systems representative.
17. Inspect wave spring (6182) for damage. If it is damaged or broken, replace as per **Section 6.1.2 - Disassemble and Reassemble Procedure (page 14)**.

NOTE: The remaining parts are the latches and latch return springs. These can be removed by knocking the roll pin out until the latch falls free. There should be no reason to remove these latches, as they should not wear significantly to require changing. If it appears that the latches or latch return springs need replacing, please contact your OPW Engineered Systems representative.



Step 9

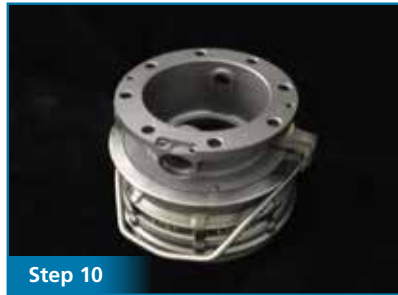

Step 10



Step 11



Step 12



Step 13



Step 14



Step 15

6.1.2 Disassemble and Reassemble Procedure (continued)



NOTE: Photos are provided for key steps

◆ = Care must be taken to ensure the quality of the unit.

Reassemble

1. Sit body on bench with the flange facing down.
2. If any of the springs (6171) came out during the disassemble procedure, inspect them for wear and replace as required. Refit the springs into the drilled holes in the body.

◆ **NOTE:** If latches do not move or operate freely, replace them or contact your local OPW Engineered Systems representative.

3. Sit body assembly on bench with flange facing up.

4. Place the collar over the body. Ensure all latches are pressed in so that the collar drops flush with the front face.
5. Place lever (API555-10) on the bottom of the coupler as per the orientation shown below.
6. Place springs (4497) into the recess of the lever, lining them up with the holes for the grub screws.



WARNING

WARNING: Wear safety glasses and install springs with caution as they might spring out during insertion.

7. Place pin springs (API800-13) into the holes of the coupler body.
8. Fit the grub screws (3227) and tighten with an Allen key so they sit below the surface of the coupler body.
9. Fit the latch release handle (API555-6) into the lever (API555-10) ensuring it is in the correct orientation as shown in the step 9 image.
10. Fit the split pins (0762) into both ends of the handle and secure by bending the longer end of the pin over (as shown in the step 10 image).
11. Replace seals on poppet adaptor ring in line with instructions in Section 3 – Replace Product Seal (page 8) and Section 4 – Replace Outer O-ring (page 9).



12. Inspect poppet (API800-9) and replace as necessary.
13. Place the poppet adaptor ring (API800-4) over the poppet (API800-9) followed by the wave spring (6182).
- ◆ **NOTE:** Ensure the wave spring (6182) is replaced before the coupler is reassembled.
14. Place body (API800-2) on top of the poppet assembly. To ensure proper orientation, ensure the back of the Camplates are facing the scallop on the body (as shown in the step 14 image).
15. Grease the sleeve using solvent-resistant grease and fit the sleeve ensuring the flat end of sleeve is facing the inside of the coupler.
16. Grease the shaft and bush assembly (API850-5Axx) and fit it, ensuring it goes through the eccentric cam and eccentric cam sleeve and sits in the sleeve at the bottom of the coupler body.
17. Push the bush and O-ring assembly past the U-pin groove.
18. Install the U-pin (API800-23) and ensure it is securely fitted.



WARNING: Wear safety glasses and install U-pin with caution as it might spring out during insertion.

19. Refit the operating handle (API800-11 or API800-15) as per the orientation shown in the step 19 image on page 17 and refit the cap screw and nyloc nut (4399), ensuring the handle is secured in place by tightening the cap screw/nyloc nut.
- ◆ **NOTE:**
 1. Ensure a new nyloc nut is used each time. Do not reuse old nyloc nut.
 2. When refitting the handle bolt, the recommended torque is 3-4 N m (this is the torque required to screw through the nyloc nut, but excessive force may damage or strip the nut threads).
20. Close the coupler operating handle and pull back the latch release handle allowing the collar to retract and click into place.



Step 13

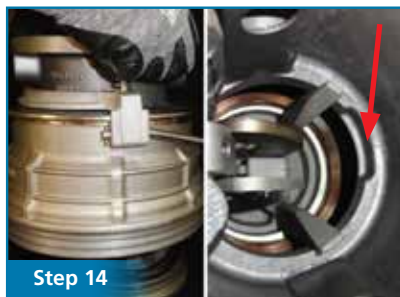

Step 14



Step 15



Step 16



Step 17



Step 18



Step 19



Step 20

8. Troubleshooting

Leaks Around Operating Shaft (API850-5A or API850-5AVG or API850-5AC or API850-5ANBR)

Leaks between the operating shaft and the bush are caused by worn or damaged O-rings on the operating shaft. Refer to Section 3 – Replace Product Seal (page 8).

Leaks Around Poppet/Poppet Adaptor Ring (API800-9/API800-4)

Leaks around the poppet adaptor ring are caused by worn or damaged O-rings in the adaptor ring. Refer to Section 4 – Replace Outer O-ring (page 9).

Leaks When Coupled With API Adaptor (Truck Valve) During Loading

This indicates the coupler product seal may be damaged or worn. Visually inspect upon disconnection from the truck valve. Also check the API adaptor (truck valve) seal face for damage or wear. If replacement of the coupler product seal is required, this can be carried out without taking the coupler valve out of service. Refer to Section 5 – Replace Product Seal (page 10).

Leaks Immediately After Disconnection With API Adaptor (Truck Valve)

This indicates the coupler product seal may be damaged or worn. Visually inspect upon disconnection from the truck valve. This could also indicate that the API adaptor poppet may be protruding excessively from the adaptor seal surface. Check the API adaptor (truck valve). If replacement of the coupler product seal is required, this can be carried out without taking the coupler valve out of service. Refer to Section 5 – Replace Bush and O-ring Assembly (page 10).

Coupler Not Latching Correctly to the Truck Adaptor

Dirt build up on the latches might prevent the coupler from latching correctly to the truck adaptor and might prevent the collar from sliding forward naturally. Remove dirt from all latches and regularly monitor.

For other issues, contact your local OPW Engineered Systems representative.

9. Spare Parts

The table below lists common spare parts for the LYNX Series couplers.

(Please refer to pages 4 - 5 for further item details.)

Part Number	Spare Part Description	Contents	Quantity required*
API850SKZ	LYNX850 All Seal Kit (Viton B)	1 x API800-1 Product Seal (Viton B) 1 x 0203 Outer O-ring (Viton B) 1 x 5805 Grease Kit 1 x API850-7A	1
API8KITZ	API800 Poppet Seal/O-ring Kit (Viton B)	1 x API800-1 Product Seal (Viton B) 1 x 0203 Outer O-ring (Viton B) 1 x 5805 Grease Kit	1
API850-7A	Bush and O-ring Assembly (Viton B)	1 x Bush and O-ring Assembly (Viton B) 1 x Nyloc Nut (4955) 1 x Shim Washer (API800-14)	1
API800-1	Product Seal (Viton B)	1 x Seal Product (Viton B)	1
0203	O-ring (Viton B)	1 x O-ring for Poppet Adaptor Ring (Viton B)	1
API850VGSKZ	API800 All Seal Kit (Viton GFLT)	1 x API800-1VG Product Seal (Viton GFLT) 1 x 0203VG Outer O-ring (Viton GFLT) 1 x 5805 Grease Kit 1 x API850-7AVG	1
API8VGKITZ	API800 Poppet Seal/O-ring Kit (Viton GFLT)	1 x API800-1VG Product Seal (Viton GFLT) 1 x 0203VG Outer O-ring (Viton GFLT) 1 x 5805 Grease Kit	1
API850-7AVG	Bush and O-ring Assembly (Viton GFLT)	1 x Bush and O-ring Assembly (Viton GFLT) 1 x Nyloc Nut (4955) 1 x Shim Washer (API800-14)	1
API800-1VG	Product Seal (Viton GFLT)	1 x Seal Product (Viton GFLT)	1
0203VG	O-ring (Viton GFLT)	1 x O-ring for Poppet Adaptor Ring (Viton GFLT)	1
API850-7ANBR	Bush and O-ring Assembly (Nitrile/Buna)	1 x Bush and O-ring Assembly (Nitrile/Buna) 1 x M6 Nyloc Nut (4955) 1 x Shim Washer (API800-14)	1
API800-1NBR	Product Seal (Nitrile/Buna)	1 x Seal Product (Nitrile/Buna)	1
0203B	O-ring (Nitrile/Buna)	1 x O-ring - Poppet Adaptor Ring (Nitrile/Buna)	1
ULT Spare Parts API850ULTSK	API 800 All Seal Kit (Ultra Low-Temp/FKM)	1x API800-1-ULT 1x 0203-ULT 2x 0250-ULT 2x 4574-ULT	1
API800-1F	Product Seal (Fluorosilicone)	1 x Seal Product (Fluorosilicone)	1
API850-7AC	Bush and O-ring Assembly (FFKM)	1 x Bush and O-ring Assembly (FFKM) 1 x M6 Nyloc Nut (4955) 1 x Shim Washer (API800-14)	1
API800-1K	Product Seal (FFKM)	1 x Seal Product (FFKM)	1
0203K	O-ring (FFKM)	1 x O-ring for Poppet Adaptor Ring (FFKM)	1
API800-23	U-pin	1 x U-pin Assembly	1
6182	Wave Spring	1 x Wave Spring	1
0762	Split Pin	1 x Split Pin	4
API725-4Z	Latch Collar Interlock Kit	4 x Latch Collar Interlock 4 x Latch Spring 4 x Latch Pin	4
0927	Spring Pin (Roll Pin) for Latches	1 x Spring Pin (Roll Pin) for Latches	4

*Quantity required for applicable models.

NOTES



OPW Global Operations

- ① OPW Corporate Headquarters
- ② OPW Fuel Management Systems
- ③ OPW Retail Fueling
- ④ OPW Engineered Systems
- ⑤ Midland Manufacturing
- ⑥ Civacon
- ⑦ PDQ Manufacturing Inc.
- ⑧ OPW Mexico
- ⑨ OPW Latin America
- ⑩ Poland/Petro Vend of Poland, Inc.
- ⑪ OPW EMEA Headquarters
- ⑫ OPW EMEA Czech Republic
- ⑬ OPW FTG Europe
- ⑭ OPW India
- ⑮ OPW Asia Pacific
- ⑯ OPW Russia
- ⑰ Liquip