

# LDP200 Series Liquid Detection Probes

Liquip's LDP200 Series liquid detection probes are used as overfill protection on road tankers and in storage tanks. The probes are compatible with existing gantry monitors and interchangeable with current probes. They improve safety with a self-checking design. Probe can be checked for operation independently.

## Operation

Sensing mechanism used is the different behaviour of a light beam in a glass prism when the prism is wet instead of dry. There is a very large difference in refractive index of air compared with petroleum liquids and this difference provides a very well defined and reliable switching point. With the probe dry, the light beam reflects back internally in the prism and in liquid the beam is refracted out into the liquid and "lost". Electronics in the probe are designed to create the light beam, detect its return or disappearance and pass that message to the Rack Monitor for appropriate response.



## Ordering Information

LDP202	2 Wire Probe, Aluminium Body	LDP202SCZ	2 Wire Probe, SS Body, Chemical Trim, Kit - FFKM Seals
LDP205	5 Wire Probe, Aluminium Body	LDP202SSZ	2 wire Probe, SS Body, Kit - Viton Seals
LDP202SS	2 Wire Probe, SS Body with Viton Seals	LDP202XLZ	2 wire Probe, Aluminium Body, Kit with LDP105-2 Long Extension
LDP205SS	5 Wire Probe, SS Body with Viton Seals	LDP202Z	2 Wire Probe, Aluminium Body, Kit - Buna Seals
LDP202SC	2 Wire Probe, SS Body with FFKM Seals	LDP205SCZ	5 Wire Probe, SS Body, Chemical Trim, Kit - FFKM Seals
LDP205SC	5 Wire Probe, SS Body with FFKM Seals	LDP205SSZ	5 Wire Probe, SS Body, Kit - Viton Seals
		LDP205XLZ	5 Wire Probe, Aluminium Body, Kit with LDP105-2 Long Extension
		LDP205Z	5 Wire Probe, Aluminium Body, Kit - Buna Seals

## Specifications



### Electrical Parameters:

IECEX:	Ui = 30V, Ii = 690mA, Pi = 9W, Ci = 105pF, Li = 0mH
Operating Temperature:	-40°C to +65°C
IP Rating:	IP66
Level Repeatability:	±0.5mm
Design Pressure:	600kPa

### Power Limit (Pi = 9W) applies:

Ii max = 690mA when Ui max = 13.04V OR  
Ii max = 300mA when Ui max = 30V

### Safety Certification

LDP202 and LDP205	<ul style="list-style-type: none"> <li>• IECEx Certificate: IECEx ITA 14.0014X</li> <li>• Marking: Ex ia IIA T4 Ga IP66 Tamb = -40°C to +65°C</li> <li>• ATEX Certificate TUV 15ATEX 7627X</li> <li>• Marking <b>CE</b> 0518  II 1 G Ex ia IIA T4 Ga Tamb = -40°C to +65°C</li> </ul>
LDP202SS, LDP205SS, LDP202SC, LDP205SC	<ul style="list-style-type: none"> <li>• IECEx Certificate: IECEx ITA 14.0014X</li> <li>• Marking: Ex ia IIA T3 Ga IP66 Tamb = -40°C to +65°C</li> <li>• ATEX Certificate TUV 15ATEX 7627X</li> <li>• Marking <b>CE</b> 0518  II 1 G Ex ia IIA T3 Ga Tamb = -40°C to +65°C</li> </ul>

Apparatus is approved to following standards: IEC60079-0:2011, IEC60079-11:2011, IEC60079-26:2006  
EN 60079-0:2012, EN 60079-11:2012, EN 60079-26:2007



**IMPORTANT: WARRANTY VOID IF PRISM RETAINER REMOVED. NO REPLACEABLE PARTS IN TIP.**

<b>MATERIALS</b>	<ul style="list-style-type: none"> <li>Aluminium probe body, retainer &amp; extension OR Stainless steel body, retainer &amp; extension, Pyrex glass prism, and epoxy.</li> <li>Viton o-rings OR FFKM o-rings</li> </ul>
<b>MAINTENANCE</b>	Irreparable item, no routine maintenance required, replace with new if found faulty.
<b>INSTALLATION</b>	<ul style="list-style-type: none"> <li>It is the requirement of the ATEX Approval that the probe is installed in such a way that the probe is electrostatically grounded. Install the grubscrew in PJB500, PJB301 &amp; VOH200-5 kit for this requirement.</li> <li>It is recommended to use Liquip PJB500, PJB301 or VOH200-5 probe holder which is compatible with Liquip manhole covers. Probe can be removed from tank top without having to access interior to remove a hood.</li> <li>Installation should be in accordance with applicable standards such as EN60079-14 and EN60079-25 or IEC60079-14 and IEC60079-25 or ANSI/ISA RP12.06.01 and ANSI/NFPA 70 or CSA C22.1 Part 1, Appendix F or equivalent.</li> <li>Users shall avoid ignition hazards due to impact or friction on the apparatus when used in Zone 0 areas.</li> <li>Any free ends of cable not connected shall be appropriately terminated to ensure no contact with additional sources of power is possible.</li> </ul>
<b>WIRING METHOD</b>	<ol style="list-style-type: none"> <li>2 - Wire System for LDP202, LDP202SS and LDP202SC Attached drawing shows a typical 6 channel compartment system based on Australian Standard. For 8 channel compartment system ask Liquip for more details.</li> <li>5 - Wire System for LDP205, LDP205SS and LDP205SC Attached drawing shows a typical 7 compartment tanker, the number of probes varies with the number of compartments in the tanker as the probes are connected in series.</li> </ol>
<b>OPERATIONAL PARAMETERS</b>	<p>Liquid properties must conform to the following:</p> <ul style="list-style-type: none"> <li>Have refractive index between 1.10 and 1.47. If in doubt, carry out test with sample of liquid at working temperatures.</li> <li>Not be reflective (e.g. milk will not trip probe as white reflects)</li> <li>Be non-gelling and remain liquid at all operational temperatures. Viscosities up to 3500 cSt, work without suffering from clingage.</li> <li>No particles in suspension which can form clinging opaque surface coating on prism.</li> <li>Use with standard petroleum products and water-based compounds only. Any other chemical content must be checked with Liquip.</li> <li>Not allow sunlight to access prism during operation.</li> <li>Not install probe, or carry out routine tests adjacent to any reflective surface. (Incident light and reflections may cause false readings)</li> </ul>
<b>HANDLING PRECAUTIONS</b>	<p>Treat with care, in particular protect tip until probe is installed. Protect open end of probe from moisture and chemicals. The probe prism is protected and light-shielded by the retainer.</p>
<b>ACCESSORIES</b>	<p>Extension bars of aluminium or stainless steel to suit various length applications. The following extension bars can only be used:</p> <ul style="list-style-type: none"> <li>LDP102-4 (80mm long)</li> <li>LDP102-4SS (80mm long stainless steel)</li> <li>LDP102-8 (Gauged, 80mm long)</li> <li>LDP105-2 (222mm long)</li> <li>LDP105-2SS (222mm long stainless steel)</li> <li>Note: LC99 extension bar is not compatible.</li> </ul>
<b>ASSOCIATED EQUIPMENT</b>	<ul style="list-style-type: none"> <li>RM100 Series Rack Monitor</li> <li>TP Series "Ground Boss" truck plug</li> <li>DP305 Dummy Probe</li> <li>DP307 Dummy Probe</li> <li>PJB301 Probe holder</li> <li>PJB500 Probe holder</li> <li>VOH200-5 Probe holder</li> </ul>

Overall dimensions shown on the drawing overleaf.



# LDP202 & LDP205

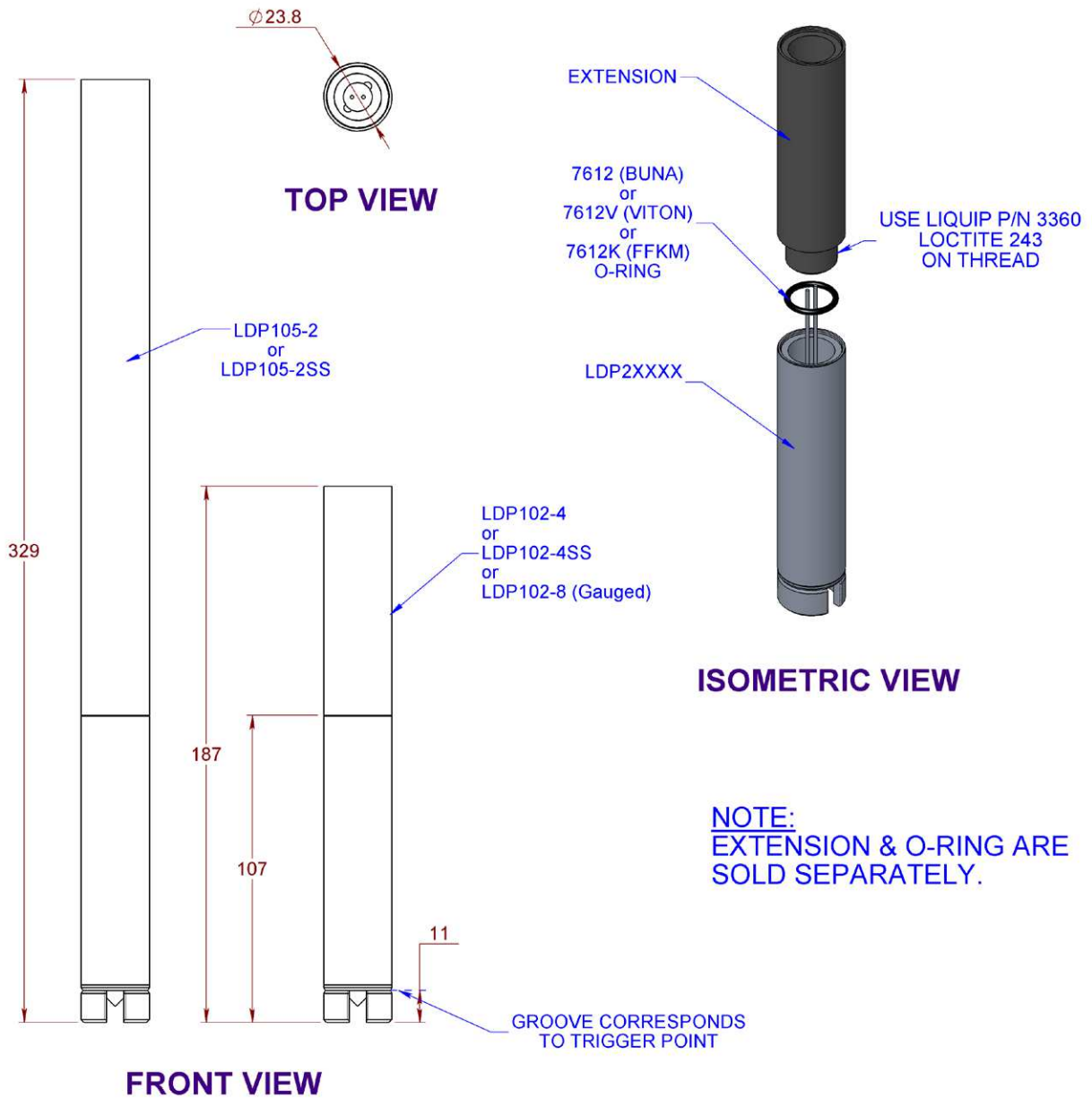

METERS - VALVES - VENTS - MANHOLES - HOSEREELS - OVERFILL PROTECTION - LOADING ARMS - ELECTRONIC DIPSTICKS



**LIQUIP INTERNATIONAL PTY LTD**  
 13 HUME ROAD SMITHFIELD SYDNEY N.S.W. AUSTRALIA 2164  
 Phone: +61 2 9725-9000 Fax: +61 2 9725-1252 Web: www.liquip.com

**X752014**

Sheet 1 of 1  
Issue: C

# OVERFILL PROTECTION WIRING (2-WIRE)

## 6 COMPARTMENTS

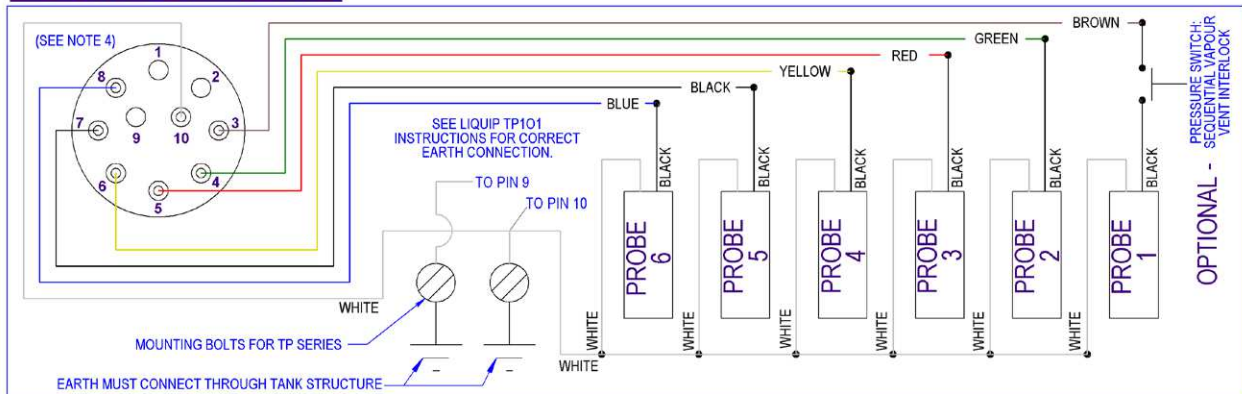

## 4 COMPARTMENTS

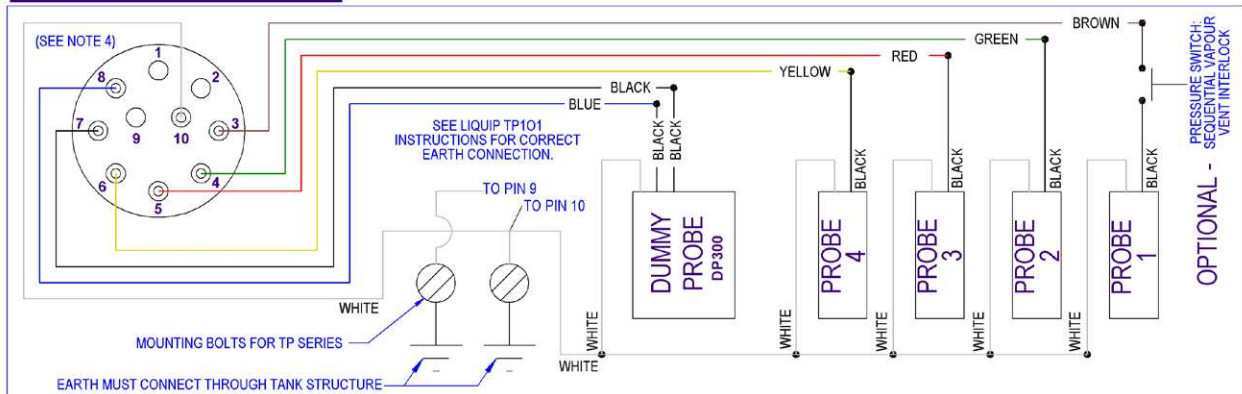

## 1 COMPARTMENT

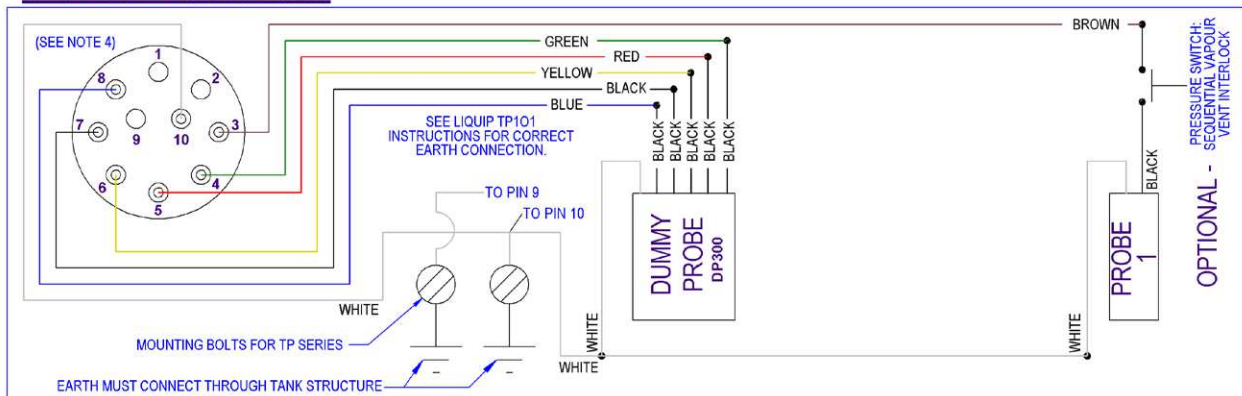

### NOTES:

1. ADDITIONAL WIRING INFORMATION ON DUMMY PROBE REFER TO DATA SHEET P4008.
2. INDUSTRY COLOUR CODING STANDARD FOR 6-COMPARTMENT TANKER IS SHOWN.
3. CHECK YOUR LOCAL COLOUR CODING STANDARD FOR 8-COMPARTMENT TANKER AND COMPATIBILITY.
4. CHECK YOUR LOCAL STANDARD ON 'TRUCK PLUG' & 'GANTRY SOCKET' FOR NUMBER OF BAYONET PINS; TP103 & GP103 HAVE 3-PIN BAYONETS AND TP104 & GP104 HAVE 4-PIN BAYONETS.
5. CHECK YOUR LOCAL REQUIREMENT FOR WIRING AND CONSIDERATION OF SPACING SHOULD BE MADE REGARDING INTRINSIC SAFETY.

METERS - VALVES - VENTS - MANHOLES - HOSEREELS - OVERFILL PROTECTION - LOADING ARMS - ELECTRONIC DIPSTICKS



**LIQUIP INTERNATIONAL PTY LTD**

13 HUME ROAD SMITHFIELD SYDNEY N.S.W. AUSTRALIA 2164  
Phone: +61 2 9725-9000 Fax: +61 2 9725-1252 Web: www.liquip.com

**X7505**

Sheet 1 of 1  
Issue: G

# OVERFILL PROTECTION WIRING (5-WIRE)

## 7 COMPARTMENTS

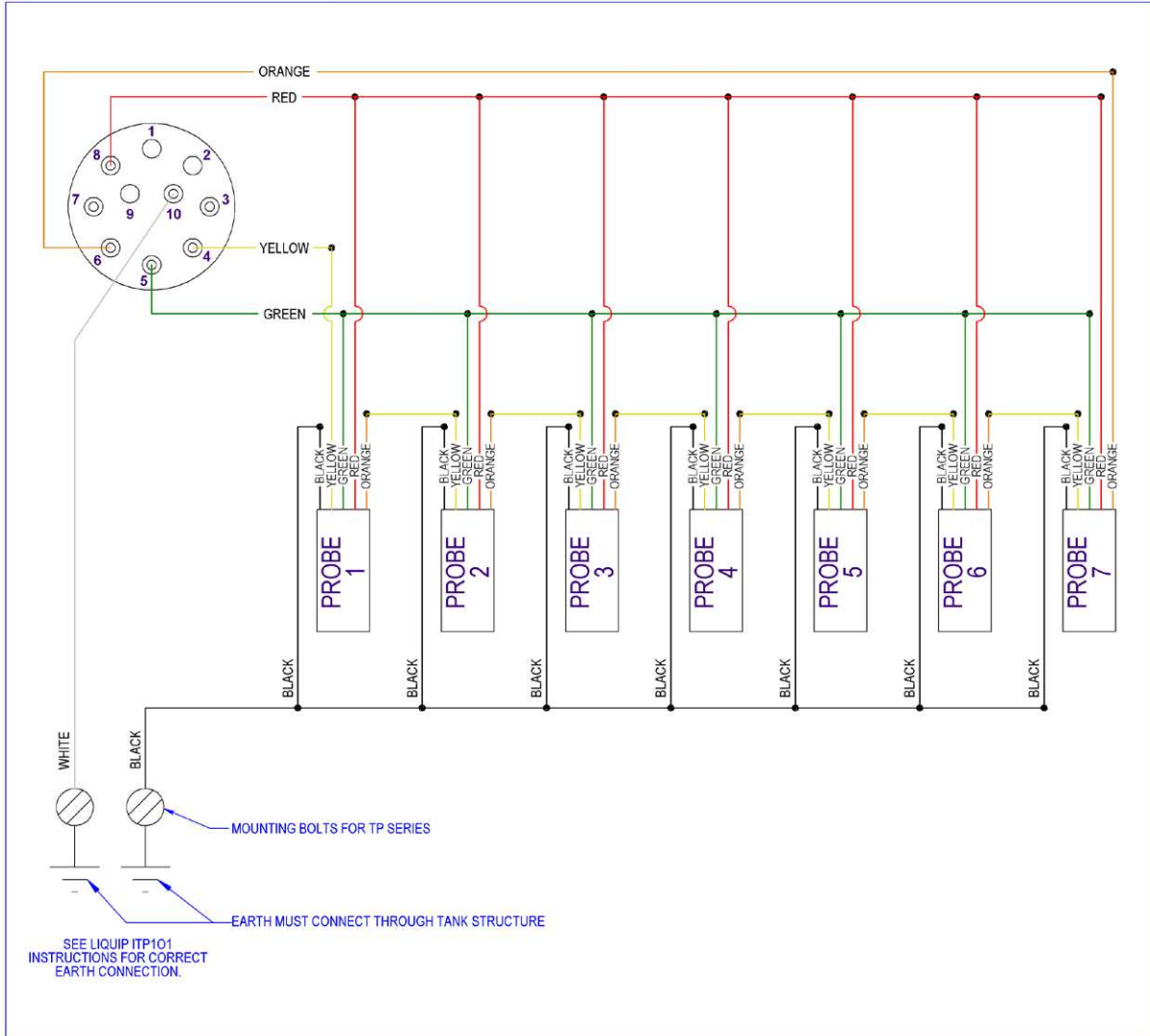

### NOTES:

1. IF GREEN BECOMES DISCONNECTED, 'PROBE DOCTOR' OPERATES CORRECTLY EXCEPT DIAGNOSTIC LIGHTS ALL BLINK.
2. CHECK YOUR LOCAL STANDARD ON 'TRUCK PLUG' & 'GANTRY SOCKET' FOR NUMBER OF BAYONET PINS.  
TP103 & GP103 HAVE 3-PIN BAYONETS AND TP104 & GP104 HAVE 4-PIN BAYONETS.
3. CHECK YOUR LOCAL REQUIREMENT FOR WIRING AND CONSIDERATION OF SPACING SHOULD BE MADE REGARDING INTRINSIC SAFETY.

METERS - VALVES - VENTS - MANHOLES - HOSEREELS - OVERFILL PROTECTION - LOADING ARMS - ELECTRONIC DIPSTICKS



**LIQUIP INTERNATIONAL PTY LTD**

13 HUME ROAD SMITHFIELD SYDNEY N.S.W. AUSTRALIA 2164  
Phone: +61 2 9725-9000 Fax: +61 2 9725-1252 Web: www.liquip.com

**X1101497**

Sheet 1 of 1  
Issue: C

# VOH200-5 KIT & INSTALLATION

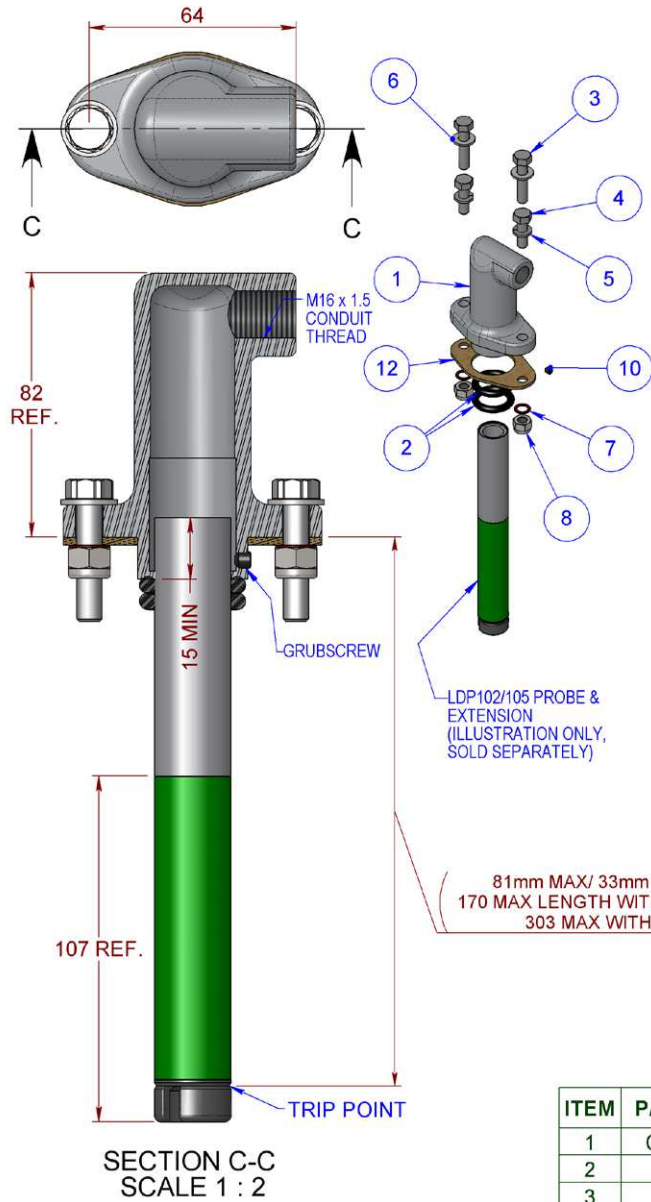

## LDP200 SERIES ASSEMBLY PROCEDURE:

1. INSTALL EXTENSION AS REQUIRED (REFER TO LDP INSTRUCTION LEAFLET P59005).
  2. SLIDE THE 2 O-RINGS (3114) OVER THE PROBE TIP AND ABOVE THE TRIP POINT AS INDICATED BY THE GROOVE. POSITION THE GASKET BETWEEN THE HOUSING AND THE MOUNTING POINT (MANHOLE COVER OR VRB-13).
  3. INSERT THE PROBE (TIP) INTO THE MOUNTING POINT (MANHOLE OR VRB-13) AND PUSH PROBE DOWN TO THE DESIRED TRIGGER POINT. TOP OF THE PROBE MUST BE 15mm MIN ABOVE THE O-RINGS. FOR LOWER SETTINGS AN EXTENSION MUST BE USED.
- NOTE: HOLD ONTO THE PROBE WIRES AND TAKE CARE NOT TO DAMAGE TIP OR DROP PROBE.**
4. CAREFULLY REMOVE THE PROBE FROM THE MOUNTING POINT AND SLIDE DOWN THE O-RINGS 3mm TOWARDS THE TIP TO ALLOW FOR O-RING BEDDING. ENSURE O-RINGS ARE STRAIGHT.
  5. THREAD THE PROBE WIRES THROUGH THE VOH200-5 HOUSING WITH THE WIRES COMING OUT OF THE ENTRY AND SLIDE THE PROBE INTO THE HOUSING, TAKING CARE NOT TO DISTURB THE O-RINGS.
  6. TIGHTEN GRUBSCREW (55056) TO APPROX 1Nm.
  7. FIT THE 2 BOLTS WITH WASHERS AND TIGHTEN EVENLY TO A TORQUE OF 15-20 Nm.
  8. CHECK THE PROBE HEIGHT.

- NOTES:**
1. WHEN MOUNTING USE APPROPRIATE FASTENERS FROM KIT (i.e. TO SUIT TAPPED OR THROUGH HOLES), DISCARD REMAINDER.
  2. GRUBSCREW IN KIT IS FOR POSITIONING PROBE HEIGHT AND FOR LDP PROBE ATEX INSTALLATION REQUIREMENTS.
  3. USE VRB-13 MOUNTING BASE IF NOT MOUNTING DIRECTLY TO A MANHOLE COVER.

ITEM	PART No.	DESCRIPTION	QTY	MATERIAL
1	C0338A	BOX JUNCTION	1	ALUMINIUM
2	3114	O-RING	2	NITRILE
3	0014	SETSCREW HEX	2	Z/P STEEL
4	0012	SETSCREW HEX	2	Z/P STEEL
5	0108	WASHER SPRING	2	Z/P STEEL
6	4334	WASHER FLAT	2	Z/P STEEL
7	4341	WASHER FIBRE	2	FIBRE
8	0149	NUT NYLOC	2	Z/P STEEL
9	6403	INSTRUCTION LEAFLET	1	PAPER
10	55056	GRUBSCREW CUP POINT	1	ST STEEL
12	3097	GASKET	1	NBR CORK

METERS - VALVES - VENTS - MANHOLES - HOSEREELS - OVERFILL PROTECTION - LOADING ARMS - ELECTRONIC DIPSTICKS



**LIQUIP INTERNATIONAL PTY LTD**  
 13 HUME ROAD SMITHFIELD SYDNEY N.S.W. AUSTRALIA 2164  
 Phone: +61 2 9725-9000 Fax: +61 2 9725-1252 Web: www.liquip.com

**X752314**

Sheet 1 of 1  
Issue: A