

# LBM800 Liquip Balance Mechanism

A new benchmark has been set for all bottom loading arms with the introduction of the LBM800. This state of the art design is essential when you require safety and long service life with minimal maintenance.

The ‘bulletproof’ LBM800 provides effortless bottom loading in petrochemical distribution depots through the use of the unique design known as the ‘Velvet Touch’.

The ability of 360° rotation in the horizontal plane allows the LBM800 to easily move from a parked to loading position to service vehicles on either side of the loading bay. While the vertical plane swivel allows users to position the coupler at different heights within the API envelope.



## Key Features

- Velvet touch provides smooth operation over the entire stroke of the loading arm.
- Long life and superior safety through Liquip’s unique gas strut design.
- Exceptional durability and minimal servicing requirements thanks to the best in class base swivel assembly and overall design.
- Any unit can be easily configured for left hand, right hand, upward and downward configurations on site.
- Slimline drop leg bracket provides easy installation and compact overall size.
- Enhanced strength and ease of adjustment through a heavy duty adjustment mechanism.
- Downtime during installation is reduced by an all flanged design.
- Outlet spool provides an industry standard 4” TTMA connection for simple installation and allows for future applications.
- Adjustable up/down stop that can be set with minimal effort.
- Viton GFLT seals fitted as standard. Other seals to suit a range of products available on request.

## Adjustment or Service

- Force adjustment is provided through spool piece adjustment bracket.
- Three hole positions on the drop bracket provide angular adjustment.
- Balancing the arm is achieved by changing strut positions.
- Up/down stop is adjustable by changing position of the locking nuts on the rod.

## Specifications

Material	Investment cast 4130 steel construction
Seals	<ul style="list-style-type: none"> <li>• Standard - Fitted with Viton GFLT seals. (Other special seals available on request)</li> <li>• Aviation - Fitted with Viton GFLT seals &amp; grease suitable for use with aviation fuel.</li> </ul>
Working Pressure	1000 kPa (145 PSI)
Test Pressure	1500 kPa (217 PSI)
Weight	60kg
Operating Temperature	-40°C to +60°C (-40°F to + 140°F)
Min & Max Moment	90 kg.m (650 ft.lb) to 250 kg.m (1800 ft.lb)
Brass Retainer Plug Thread	¼” UNF
Up / Down Angular Movement	-15° to +15° (From horizontal)
Typical Horizontal Spacing	650mm (24”)
Typical Vertical Spacing	450mm (18”)
Typical Radius of arm	1300mm to 2000mm (50” to 80”)
Typical No. of arms per bay	6
Installation & Maintenance	See LBM800 Fitting and Maintenance Instructions (P/N-59102).
Ordering Information	<ul style="list-style-type: none"> <li>• LBM800 - Standard Balance Mechanism</li> <li>• LBM800AVI - Aviation Balance Mechanism</li> <li>• LBM800-1Z - LBM800 with 2 X 2800N Struts</li> <li>• LBM800-2Z - LBM800 with 2 X 5200N Struts</li> <li>• LBM800-3Z - LBM800 with 2800N &amp; 5200N Strut</li> </ul>
Associated Equipment	<ul style="list-style-type: none"> <li>• VNI-A4VG - 4” Intermediate Swivel, Viton GFLT for Loading Arm</li> <li>• VNC-A4VG - 4” Coupler Swivel, Viton GFLT for Loading Arms</li> <li>• LYNX Series Coupler</li> </ul>

# LBM800 - CONFIGURATION & DIMENSIONS

## LBM800 - LIQUIP BALANCE MECHANISM



LEFT HAND  
UPWARD FEED INLET



LEFT HAND  
DOWNWARD FEED INLET



RIGHT HAND  
DOWNWARD FEED INLET



RIGHT HAND  
UPWARD FEED INLET

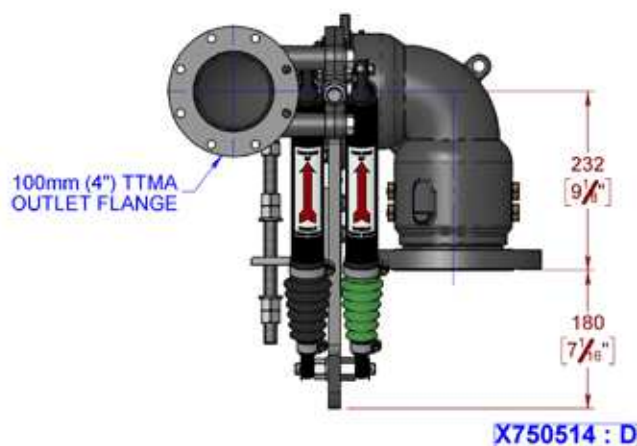
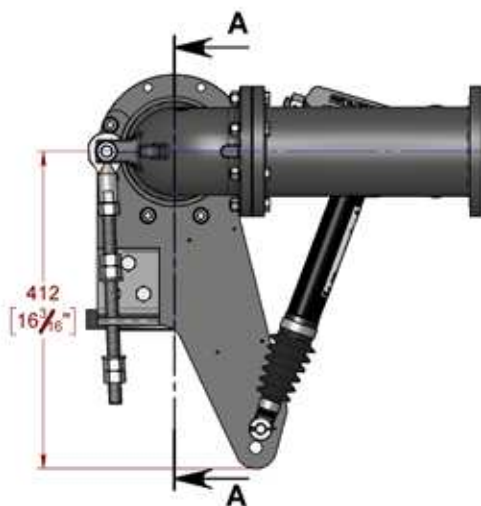
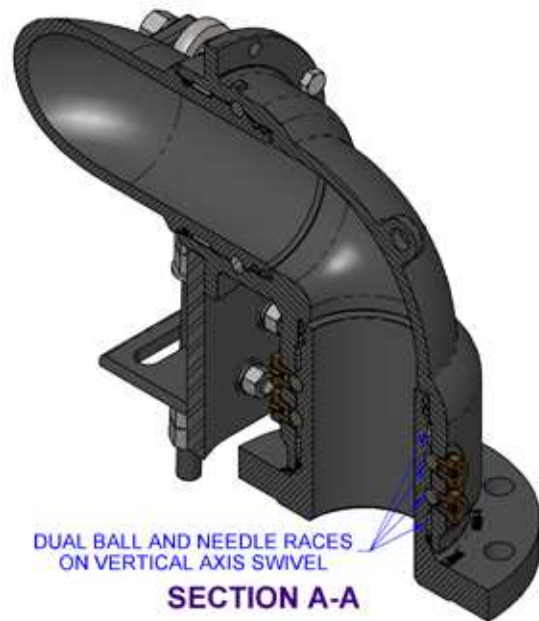
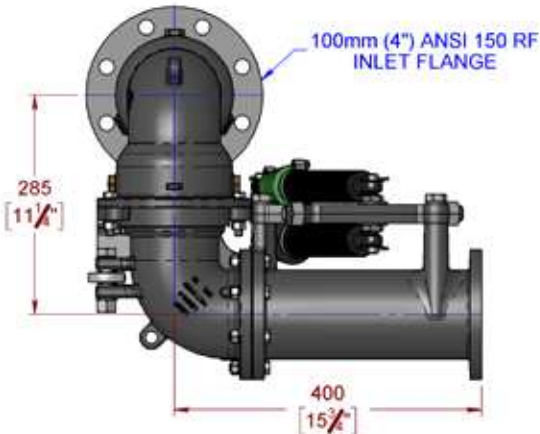

METERS - VALVES - VENTS - MANHOLES - HOSEREELS - OVERFILL PROTECTION - LOADING ARMS - ELECTRONIC DIPSTICKS



**LIQUIP INTERNATIONAL PTY LTD**  
13 HUME ROAD SMITHFIELD SYDNEY N.S.W. AUSTRALIA 2164  
Phone: +61 2 9725-9000 Fax: +61 2 9725-1252 Web: www.liquip.com

**X750514**  
Sheet 1 of 4  
Issue: D

# LBM800 - EXPLODED VIEW

## LBM800 - LIQUIP BALANCE MECHANISM



METERS - VALVES - VENTS - MANHOLES - HOSEREELS - OVERFILL PROTECTION - LOADING ARMS - ELECTRONIC DIPSTICKS



**LIQUIP INTERNATIONAL PTY LTD**  
 13 HUME ROAD SMITHFIELD SYDNEY N.S.W. AUSTRALIA 2164  
 Phone: +61 2 9725-9000 Fax: +61 2 9725-1252 Web: www.liquip.com

**X750514**

Sheet 2 of 4  
 Issue: D

## LBM800 - PARTS LIST

<b>LBM800 - LIQUIP BALANCE MECHANISM</b>				
ITEM	PART No	DESCRIPTION	QTY.	MATERIAL
1	LBM800-1	MALE STRAIGHT	1	CAST STEEL
2	LBM800-2	ELBOW FEMALE	1	CAST STEEL
3	LBM800-3	OUTLET ELBOW	1	CAST STEEL
4	0885	WASHER FIBRE	6	FIBRE
5	SJW100-3	BALL RETAINER PLUG	6	BRASS
6	6696	GRUBSCREW CUP POINT	3	ST STEEL
7	4480	SPRING COMPRESSION	3	ST STEEL
8	6688	SCREW RETAINING	3	BRASS
9	4580	BALL BEARING	3	STEEL
10	0208VG	O-RING	4	VITON GFLT
11	7619	O-RING	2	H.A.N.
12	2334	BALL BEARING	96	STEEL
13	4531	NEEDLE ROLLER	282	STEEL
14	LBM800-9	OUTLET SPOOL	1	CAST STEEL
15	0657DMV	GASKET TTMA 100mm (4")	1	VITON A
16	6745	BOLT METRIC	8	Z/P STEEL
17	6744	NUT METRIC	8	Z/P STEEL
18	5261	WASHER SPRING	13	Z/P STEEL
19	5288	WASHER FLAT	13	Z/P STEEL
20	LBM800-10	BRACKET ADJUSTER - ASSEMBLY LBM8xx	1	CAST STEEL
21	4359	WASHER FLAT	4	Z/P STEEL
22	4871	SPLIT PIN	4	ST STEEL
23	4054	BOLT METRIC	3	Z/P STEEL
24	5359	WASHER SPRING	4	Z/P STEEL
25	LBM800-7	DROP BRACKET	1	STEEL
26	LBM800-17	BRACKET-UP DOWN STOP	1	STEEL
27	LBM800-11	PIVOT PIN BOTTOM	1	Z/P STEEL
28	5361	WASHER FLAT	3	Z/P STEEL
29	4055	NUT METRIC FINE	1	Z/P STEEL
30	59104	LABEL ID - LOADING ARMS	1	ALUMINIUM
31	0005	POP RIVET	4	ALUMINIUM
32	4020	SETSCREW METRIC	5	Z/P STEEL
33	0055	NUT METRIC	5	Z/P STEEL
34	2936	BOLT METRIC	3	Z/P STEEL
35	5266	WASHER FLAT	3	Z/P STEEL
36	5280	WASHER SPRING	3	Z/P STEEL
37	4971	NUT METRIC	3	Z/P STEEL
38	4052	ROD END - UP/DOWN STOP	1	Z/P STEEL
39	LBM800-14	UP DOWN STOP	1	Z/P STEEL
40	4053	BOLT METRIC	1	Z/P STEEL
41	1076	NUT METRIC	6	Z/P STEEL
42	4416	LIFT-O-MAT STRUT	AS REQD	STEEL
43	3008	LIFT-O-MAT STRUT	AS REQD	STEEL

**X750514 : D**

METERS - VALVES - VENTS - MANHOLES - HOSEREELS - OVERFILL PROTECTION - LOADING ARMS - ELECTRONIC DIPSTICKS



**LIQUIP INTERNATIONAL PTY LTD**  
 13 HUME ROAD SMITHFIELD SYDNEY N.S.W. AUSTRALIA 2164  
 Phone: +61 2 9725-9000 Fax: +61 2 9725-1252 Web: www.liquip.com

**X750514**  
 Sheet 3 of 4  
 Issue: D

# LBM800 - SPARE PARTS

## LBM800 - LIQUIP BALANCE MECHANISM

### SPARE PARTS FOR LBM800



**LBM800-100**  
COMPLETE SWIVEL ASSEMBLY  
SIMPLE BOLT-IN REPLACEMENT



**LBM800-ABA**  
ADJUSTER BRACKET ASSEMBLY  
WITH MOUNTING BOLTS



**LBM800-UDL**  
UP/DOWN LIMITER BOLT  
WITH MOUNTING FASTENERS



**LBM800-VSK**  
BEARING & SEAL COMPONENTS  
FOR VERTICAL AXIS SWIVEL



**LBM800-HSK**  
BEARING & SEAL COMPONENTS  
FOR HORIZONTAL AXIS SWIVEL



**LBM800-ASK**  
O-RING SEAL COMPONENTS  
FOR BOTH SWIVELS



**4416**  
LIFTOMAT STRUT  
2800N  
(BLACK BOOT)



**3008**  
LIFTOMAT STRUT  
5200N  
(GREEN BOOT)



**LBM800-PPA**  
PIVOT PIN ASSEMBLY  
FOR LOWER STRUT MOUNT



**0657DMV**  
100mm VITON TTMA GASKET  
BETWEEN SWIVEL & OUTLET

**X750514 : D**

METERS - VALVES - VENTS - MANHOLES - HOSEREELS - OVERFILL PROTECTION - LOADING ARMS - ELECTRONIC DIPSTICKS



**LIQUIP INTERNATIONAL PTY LTD**  
13 HUME ROAD SMITHFIELD SYDNEY N.S.W. AUSTRALIA 2164  
Phone: +61 2 9725-9000 Fax: +61 2 9725-1252 Web: www.liquip.com

**X750514**  
Sheet 4 of 4  
Issue: D