

Liquip Overfill Protection System Tester - 5-Wire

DATA SHEET

PART N°: HTA503

TITLE:	Portable tester for truck and gantry 5-wire overfill protection systems.
PURPOSE:	To enable testing of truck systems, gantry systems and individual probes for quick and effective fault-diagnosis. Also includes "ground assurance" test button for gantry diagnosis.
OPERATION:	Connect the system or probe to the appropriate connector supplied in the equipment box. Follow instructions on the label in the lid and press the 'Test' button. Clearly labelled diagnostic lights indicate if there is a fault and what the fault is. Indications include short circuit and open circuit in the wiring, a faulty probe and the tank compartment number.
DISMANTLE:	The only operation is changing the battery. Remove the four screws on the periphery of the front panel and lift clear, with care, to access the battery cover and connectors.
ADJUSTMENT:	None.
TECHNICAL DATA:	<p>Diagnoses all common probes and gantry monitors using the 5-wire system. Battery is 12v lantern type. See technical use manual for full details.</p> <p>Gantry plug and truck socket are three-bayonet type. Temperature range -20°C to +70°C.</p>
WEIGHT:	6.0 kg
MATERIAL OF CONSTRUCTION:	Sturdy aluminium briefcase type box with carry handle and latch and lock lid. All necessary fittings are contained within the box with solid-state electronics mounted to an aluminium control panel. Gantry plug and truck plug are polyurethane and anodised aluminium respectively with self-store 10 core cable.
ASSOCIATED EQUIPMENT:	HTA 204 - equivalent 2-wire system tester.

Overall dimensions shown on the drawing overleaf.

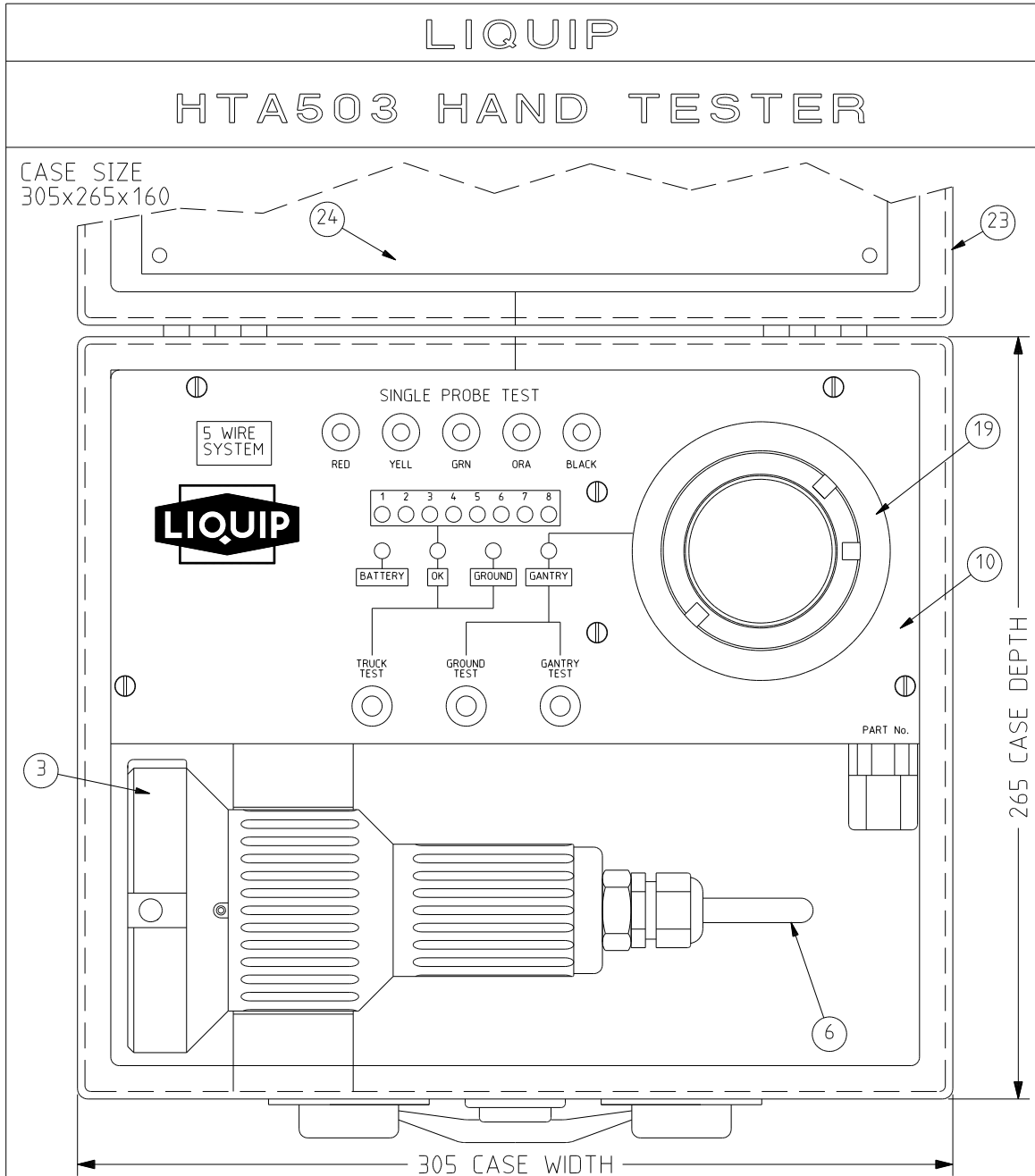

ITEM	PART NO	DESCRIPTION	QTY	MATERIAL
3	GP103-3	GANTRY PLUG ASSY 3 PIN	1	POLYURETHANE
6	5045	SELF STORE CABLE	1	ELECTRICAL
10	5049	BATTERY ASSEMBLY 12V	1	ELECTRICAL
19	TP103-3	PLUG 3 SLOT	1	ALUMINIUM
23	HTA503-1	EXTRUDED CASE	1	ALUMINIUM
24	5053	LABEL-OPERATING INSTRUCTION	1	PLASTIC

X550297

Issue: H

METERS - VALVES - VENTS - MANHOLES - PUMPS - HOSEREELS - OVERFILL PROTECTION - LOADING ARMS - ELECTRONIC DIPSTICKS



LIQUIP INTERNATIONAL PTY LTD

13 Hume Road
 Smithfield, Sydney
 NSW Australia 2164
 Phone: +61 2 9725 9000
 Fax: +61 2 9725 1252

DISTRIBUTORS

See inside front cover
 for Liquip branches
 and Distributors or visit

www.liquip.com

LIQUIP

HTA503 PLUG CONNECTIONS

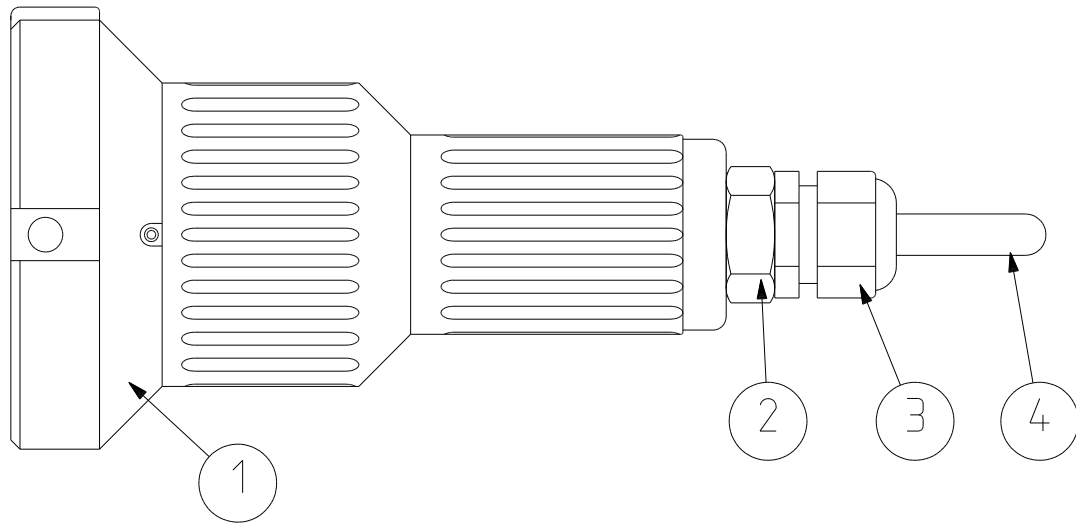

ITEM	PART NO	DESCRIPTION	QTY	MATERIAL
1	GP103-3	GANTRY PLUG ASSY 3 PIN	1	SUB.ASS.
2	7834	ADAPTOR BRASS M25 TO M20 M/F	1	BRASS
3	5060	CABLE GLAND M20	1	PLASTIC
4	5045	SELF STORE CABLE	1	ELEC

COLOUR CODING

- 1 - BROWN
- 2 - PINK
- 3 - BLUE
- 4 - YELLOW
- 5 - GREEN
- 6 - ORANGE
- 7 - VIOLET
- 8 - RED
- 9 - WHITE
- 10 - BLACK

X550697

Issue: B

METERS - VALVES - VENTS - MANHOLES - PUMPS - HOSEREELS - OVERFILL PROTECTION - LOADING ARMS - ELECTRONIC DIPSTICKS



LIQUIP INTERNATIONAL PTY LTD

13 Hume Road
 Smithfield, Sydney
 NSW Australia 2164
 Phone: +61 2 9725 9000
 Fax: +61 2 9725 1252

DISTRIBUTORS

See inside front cover
 for Liquip branches
 and Distributors or visit

www.liquip.com