

DACouplings®
Dry Aviation Couplings



Product Information

Content

| | |
|--|------|
| About NPT and BSP threads | 22 |
| Advantages | 6 |
| Drain Connection | 16 |
| Dust plug and cap | 17 |
| Enquiry DACouplings | 27 |
| Explanation of Designations - 1/2 | 25 |
| Explanation of Designations - 2/2 | 26 |
| Filter Strainer - Product information | 9-10 |
| Flange Measurement - 1/2 | 19 |
| Flange Measurement - 2/2 | 20 |
| Flange Connection | 21 |
| Flat seals for thread - 1/2 | 23 |
| Flat seals for thread- 2/2 | 24 |
| Hose unit with female thread | 7 |
| Hose Unit Option - Long Handle | 8 |
| Hose Unit Option - Half long Handle | 8 |
| Hose Unit Option - Depot Handle | 8 |
| How it works | 3 |
| ISO 45 with Ground Connection | 10 |
| Military | 18 |
| Pressure Drop Curve | 3 |
| Pressure Drop Measurement | 4 |
| Pressure equalizing valve | 5 |
| Pressure relief valve | 5 |
| Tank unit with female thread | 11 |
| Tank unit with male thread | 11 |
| Tank unit with standard flange, 2½" ASA 150 psi | 12 |
| Tank unit with standard flange, 3" ASA 150 psi | 12 |
| Tank unit with standard flange, DN 65 PN 10/16 | 13 |
| Tank unit with standard flange, DN 80 PN 10/16i | 13 |
| Tank unit with standard flange, TW1 (DIN 28459) | 14 |
| Tank unit with standard flange, TW3 (DIN 28459) | 14 |
| Tank unit with standard flange, 3" TTMA | 15 |
| Tank unit with standard flange, 4" TTMA | 15 |
| Tank unit with square flange, 120 mm / 4.72 inch | 16 |
| Technical Data | 17 |

How it works

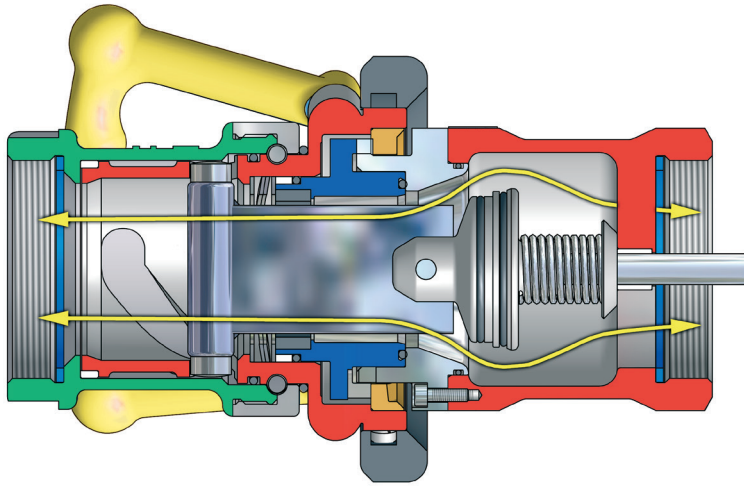

To connect
Push and turn -
it's coupled - *full flow*

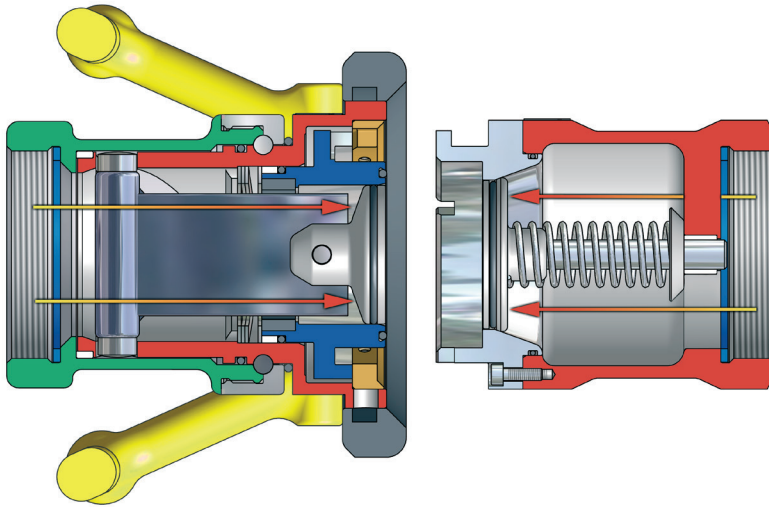

To disconnect
Turn and pull -
it's released
- *no spillage*

Pressure Drop Curve

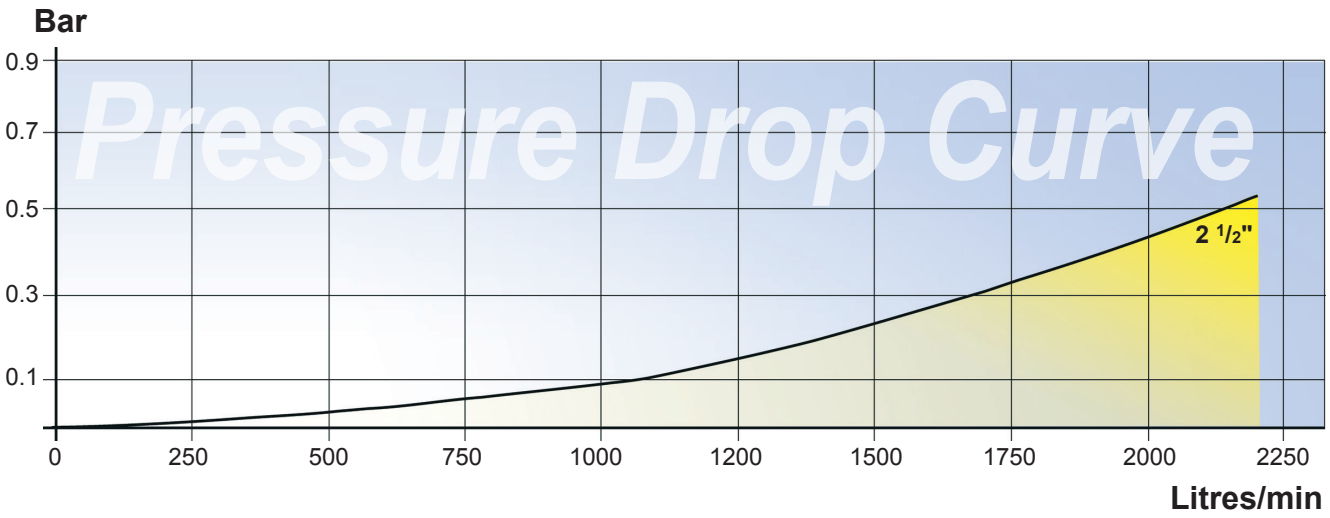

Test Fluid: n-Paraffin, **Test Temperature:** 20° C, **Density:** 0,75 kg / dm³, **Viscosity:** 1,75 mm²/s

No part of this leaflet may be reproduced in any form or by any means without permission in writing from the publisher.

Illustration Pressure Drop Measurement According to NATO STANAG 3756, Annex E

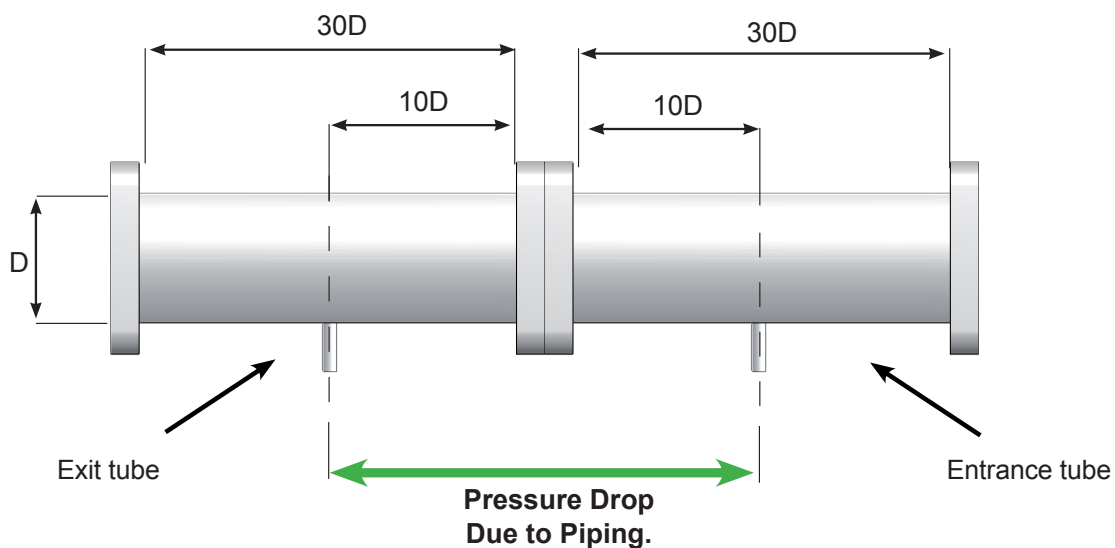
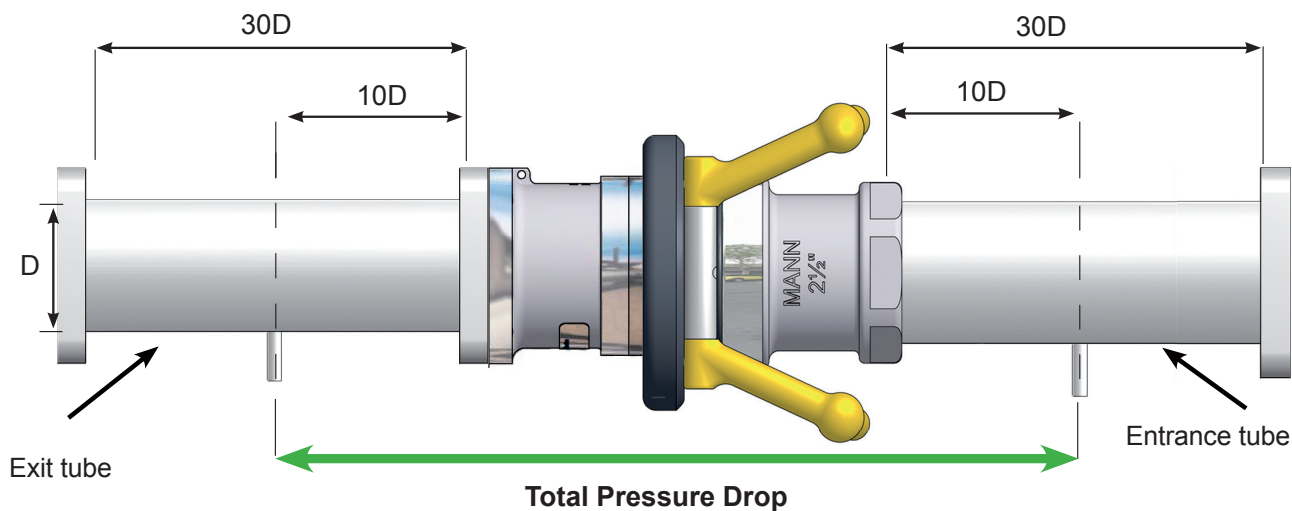

Pressure Drop DACoupling (ISO45) = Total Pressure Drop - Pressure Drop Due to Piping

$$\text{Pressure Drop DACoupling} = \Delta P$$

Pressure equalizing valve Tank unit and Tank unit

Pressure equalizing valve in ISO 45 Tank unit and STANAG 3756 Tank unit

This system dissipates trapped fluid pressure into hose coupler without spillage, to allow easy connection.

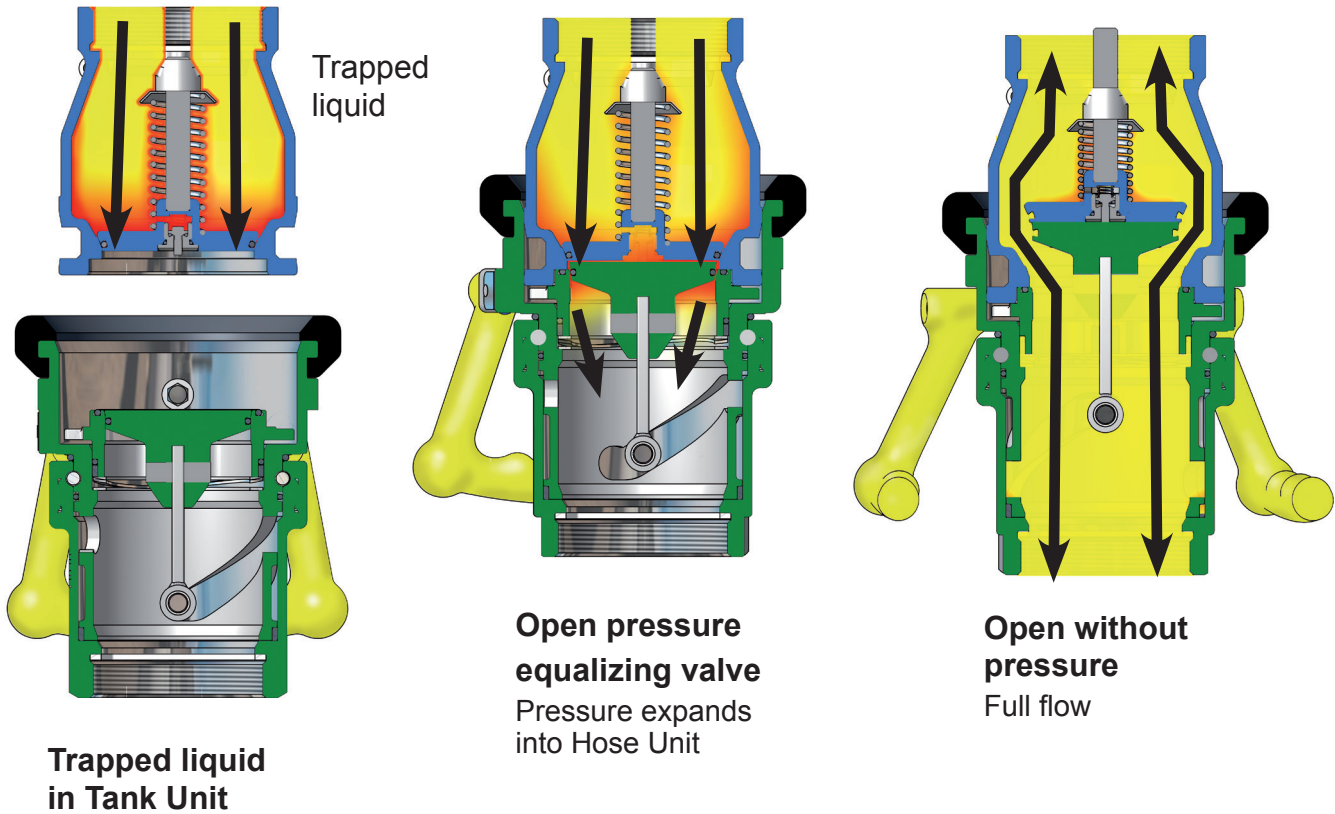

Pressure relief valve in ISO 45 Tank unit and STANAG 3756 Tank unit

Pressure Relief Valve (relieve valve, blow off valve)

Under thermal influence the liquid will be warmed up and the pressure increases extremely. To protect the equipment against excessive pressure the PEV opens at a predetermined pressure at an acceptable and riskless limit.

Other applications with the same effect are adapter pieces between different DDCs, hose lines with DACouplings on both sides e.g. for military applications (logistic supply lines).



No part of this leaflet may be reproduced in any form or by any means without permission in writing from the publisher.

Advantages - All wetted parts in Aluminium and Stainless steel

No yellow parts (Brass and Bronze) in contact with the fuel.

The Tank unit is supplied with parallel BSP threads and flat sealing surface. This allows the use of the full thread length for screwed-on parts. Also available with flange and tapered internal NPT threads.

PTFE (Teflon®) bearing between the piston shaft and the piston guide to eliminate the risk of seizure.

Conical valve seat to eliminate the risk for "piston blow out" when extreme pressure is used.

Coupling ring in brass to minimize the risk of seizure. All parts with media contact are Stainless steel or Aluminium.

PTFE (Teflon®) bearings between the driving plate and the piston guide to eliminate the risk of seizure.

Shaft journal in Stainless Steel embedded in PTFE (Teflon®) to eliminate seizure.

Inner parts in Stainless Steel AISI 316.

Protecting ring in weather resistant rubber. Electrically conductive.

Riveted piston pin to minimize the risk of failure under extreme pressure conditions.

Ball bearings in Stainless Steel.

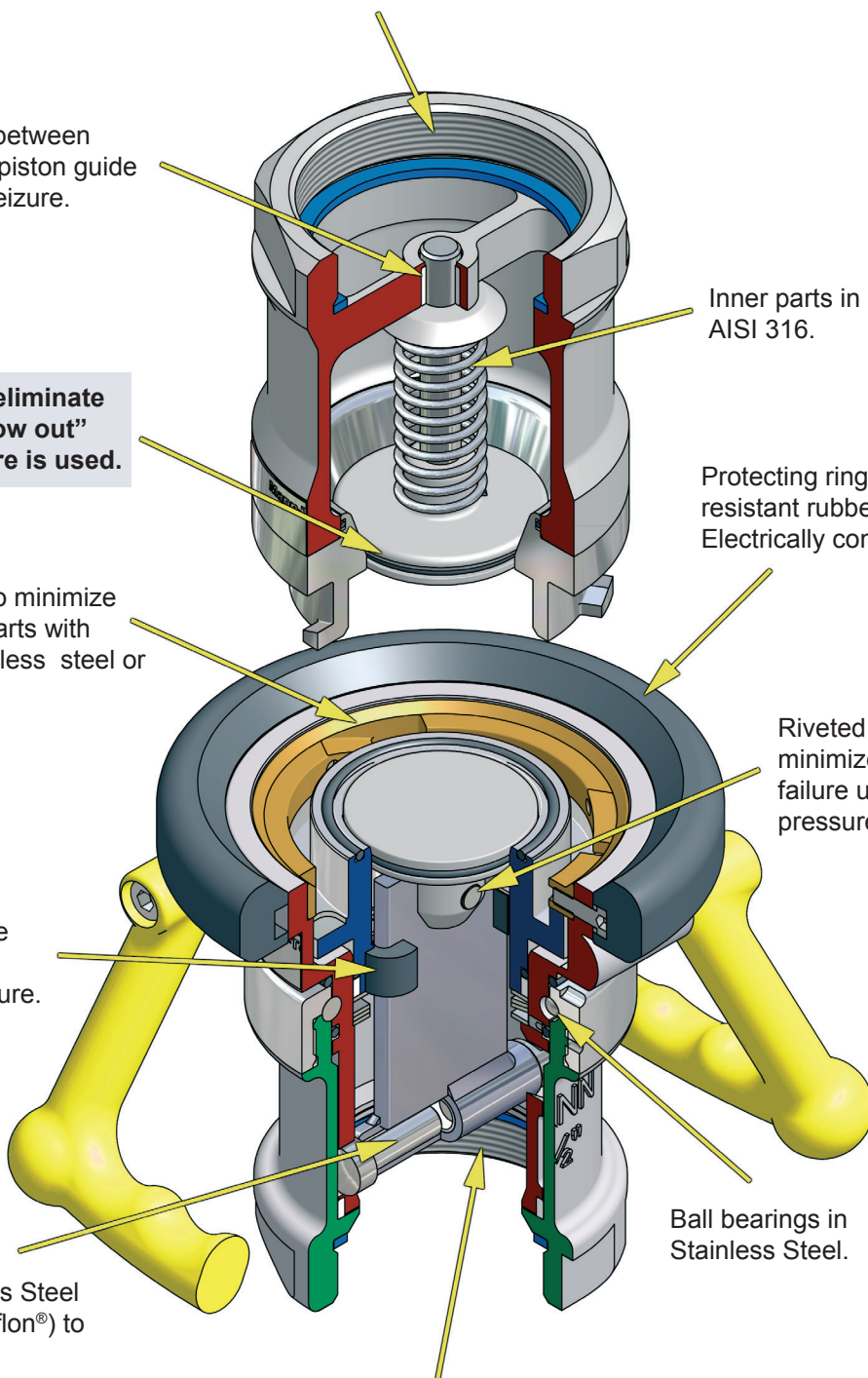

The Hose unit is supplied with parallel BSP threads and flat sealing surface. This allows the use of the full thread length for screwed-on parts. Also available with flange and tapered internal NPT threads.

Teflon® is a registered trademark of DuPont.

No part of this leaflet may be reproduced in any form or by any means without permission in writing from the publisher.

Hose unit with female thread - Standard Handle

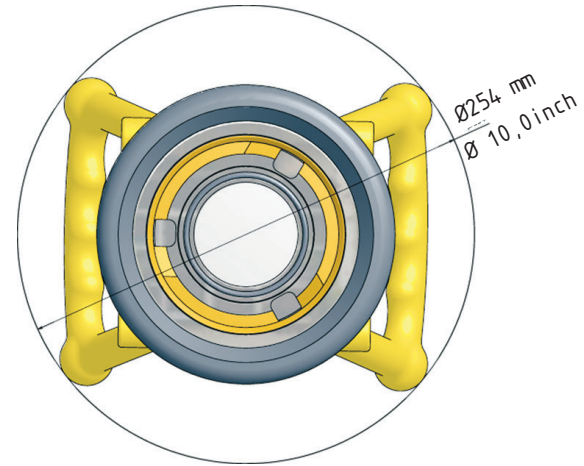
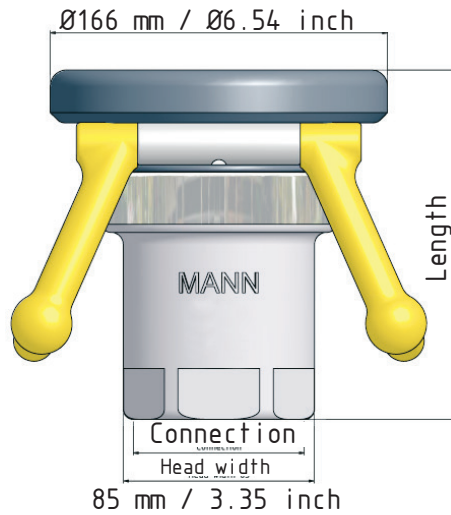
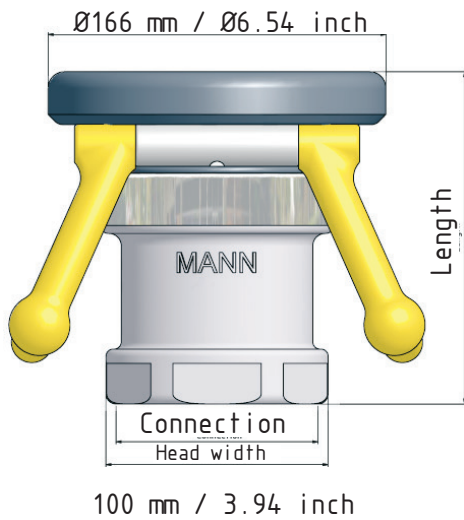

Threads:

BSP = ISO 228

NPT = B1.20.1

| Connection | Length | Head width | Weight | Code No |
|------------|------------------|--------------------|------------------|-------------------|
| 2½" BSP | 64 mm/6.46 inch | 85 mm / 3.35 inch | 3.4 kg / 7.5 lbs | F312B1101B |
| 3" BSP | 164 mm/6.46 inch | 100 mm / 3.94 inch | 3.5 kg / 7.7 lbs | F314B1101B |
| 2½" NPT | 172 mm/6.77 inch | 85 mm / 3.35 inch | 3.4 kg / 7.5 lbs | F313B1101 |
| 3" NPT | 174 mm/6.85 inch | 100 mm / 3.94 inch | 3.5 kg / 7.7 lbs | F315B1101 |

Hose Unit, flanged inlet

| Flange1) | Material | Seal O-ring | Code No |
|-----------------------|-----------|--|------------------|
| undrilled Ø210 mm | Al | Standard FPM/KFM (Viton®) | F320B1101 |
| DN 65 PN 10/16 Type A | | | F333B1101 |
| DN 80 PN 10/16 Type A | | | F336B1101 |
| 2½" ASA 150 psi | | | F359B1101 |
| 3" ASA 150 psi | | | F361B1101 |
| TW1 (DN80) | | | F365B1101 |
| TW3 (DN100) | | | F366B1101 |
| 3" TTMA | | | F367B1101 |
| 4" TTMA | | | F368B1101 |

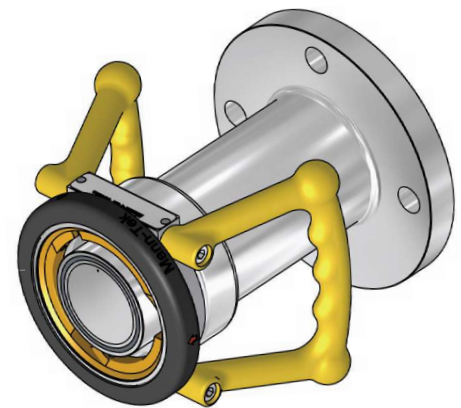

We make specials

Other materials, connection and sealings on request.

1) Flanges according to EN 1092 , ANSI B16.5 and DIN 28459.

Viton® (FPM) and Teflon® (FPM/KPM) are registered trademarks of DuPont, DuPont Elastomers. Vulkollan® is registered trademark of Bayer AG

Hose Unit Option - Long Handle

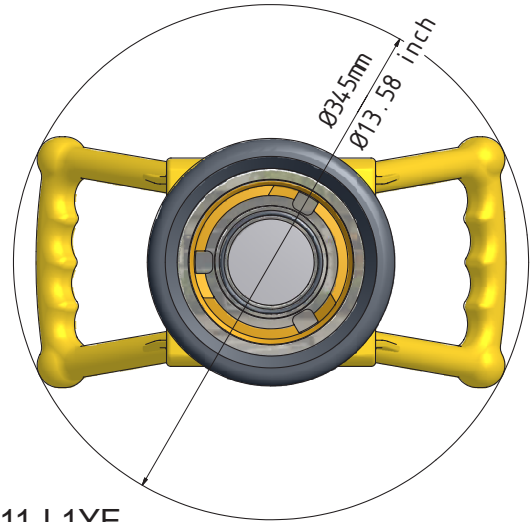
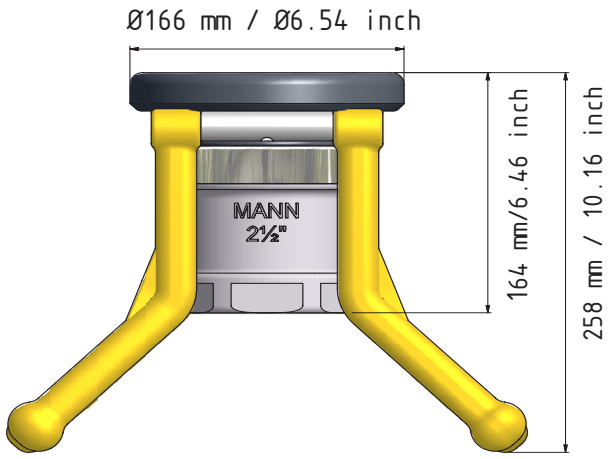

How to Order Code nr: Code nr. Hose Unit + H-F3-11-L1YE

Hose Unit Option - Half long Handle

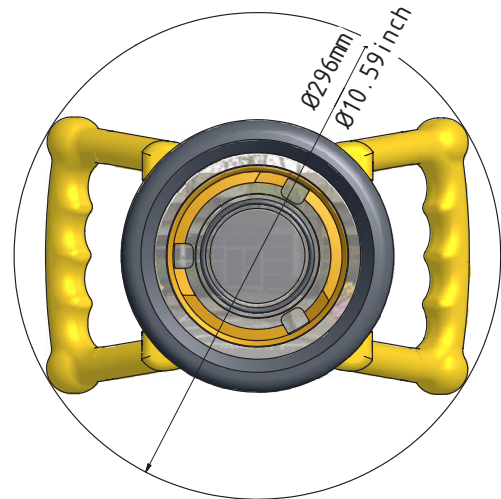
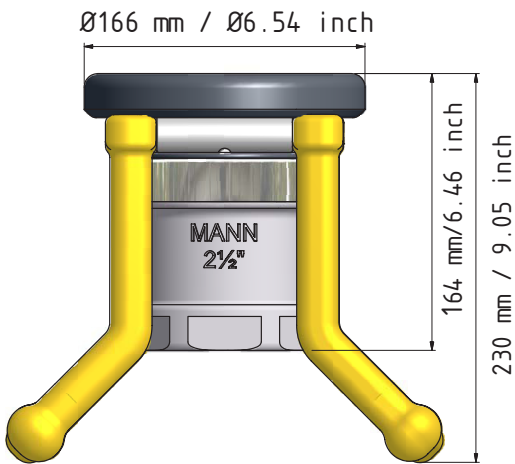

How to Order Code nr: Code nr. Hose Unit + H-F3-11-L2YE

Hose Unit Option - Depot Handle

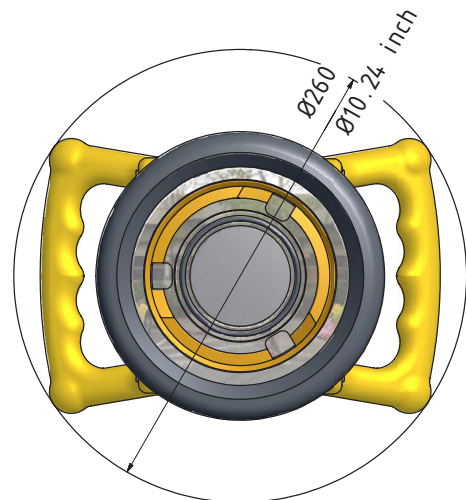
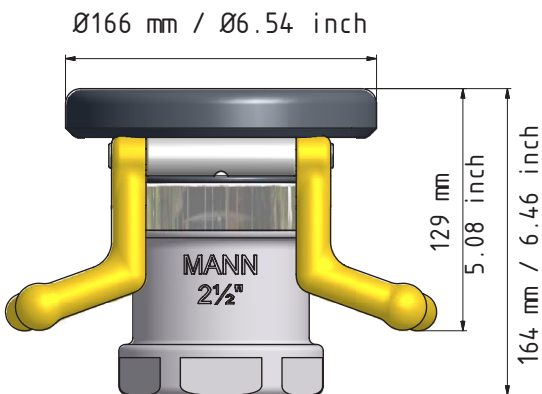

How to Order Code nr: Code nr. Hose Unit + H-F3-11-L3YE

Filter Strainer - Product information



45 mesh

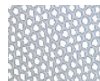

60 mesh

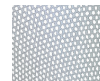

100 mesh

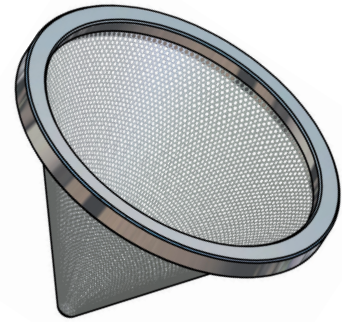
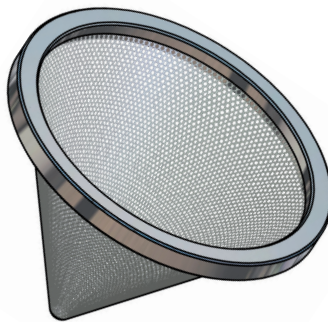
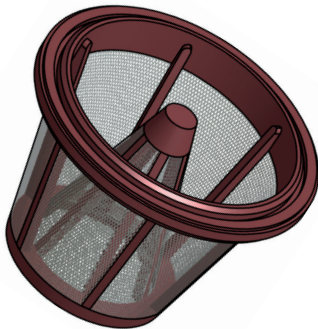

Standard connections:

Other combinations or connections on request.

| Size | End connection (female) | HU connection (male) |
|---------------|-------------------------|----------------------|
| U1280S1101-XX | 2½" BSP | 2½" BSP |
| U1281S1101-XX | 2½" BSP | 2½" NPT |
| U1380S1101-XX | 2½" NPT | 2½" BSP |
| U1381S1101-XX | 2½" NPT | 2½" NPT |
| U1482S1101-XX | 3" BSP | 3" BSP |
| U1483S1101-XX | 3" BSP | 3" NPT |
| U1582S1101-XX | 3" NPT | 3" BSP |
| U1583S1101-XX | 3" NPT | 3" NPT |

ISO 45 with Ground Connection

Electrostatic charges can be generated by a variety of circumstances. Ignition of flammable vapours is possible by discharge of static.

Electrical conductive hoses and anti-static additives reduces the risk but might not be sufficient. Than the aircraft, the fuelling vehicle, and all accessories including hose nozzle, filters and other equipment through which the fuel passes must all be electrically bonded.

Such connections must always be attached to appropriate bonding connections thus providing a conductive path to equalize potential.

Removal of the bonding connection must always be the last operation.



Ground cable assembly with solid brass clamp and bold. Cable with plastic coating.

Tank unit with female thread

Body material in aluminium and stainless steel.

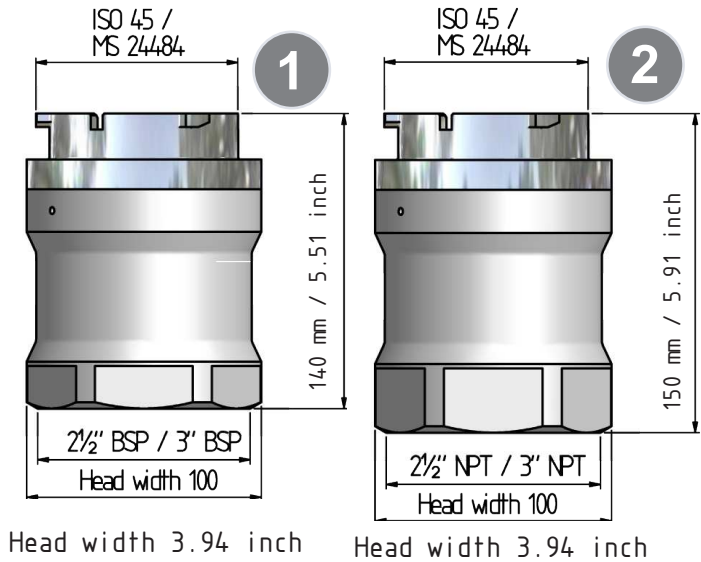

| Connection | Material | Weight | Code No |
|--------------|----------|------------------|------------|
| 1 2 1/2" BSP | AL | 2.3 kg / 5.1 lbs | G312A1401B |
| 1 3" BSP | | 2.3 kg / 5.1 lbs | G314A1401B |
| 2 2 1/2" NPT | | 2.3 kg / 5.1 lbs | G313A1401B |
| 2 3" NPT | | 2.3 kg / 5.1 lbs | G315A1401B |
| 2 1/2" BSP | SS | - | G312A4401B |
| 3" BSP | | - | G314A4401B |
| 2 1/2" NPT | | - | G313A4401B |
| 3" NPT | | - | G315A4401B |

| Working pressure: | Test pressure: |
|-------------------|------------------|
| 10 bar / 150 psi | 15 bar / 225 psi |
| Threads: | |
| BSP = ISO 228, | NPT = B1.20.1 |

Tank unit with male thread

Body material in aluminium and stainless steel.

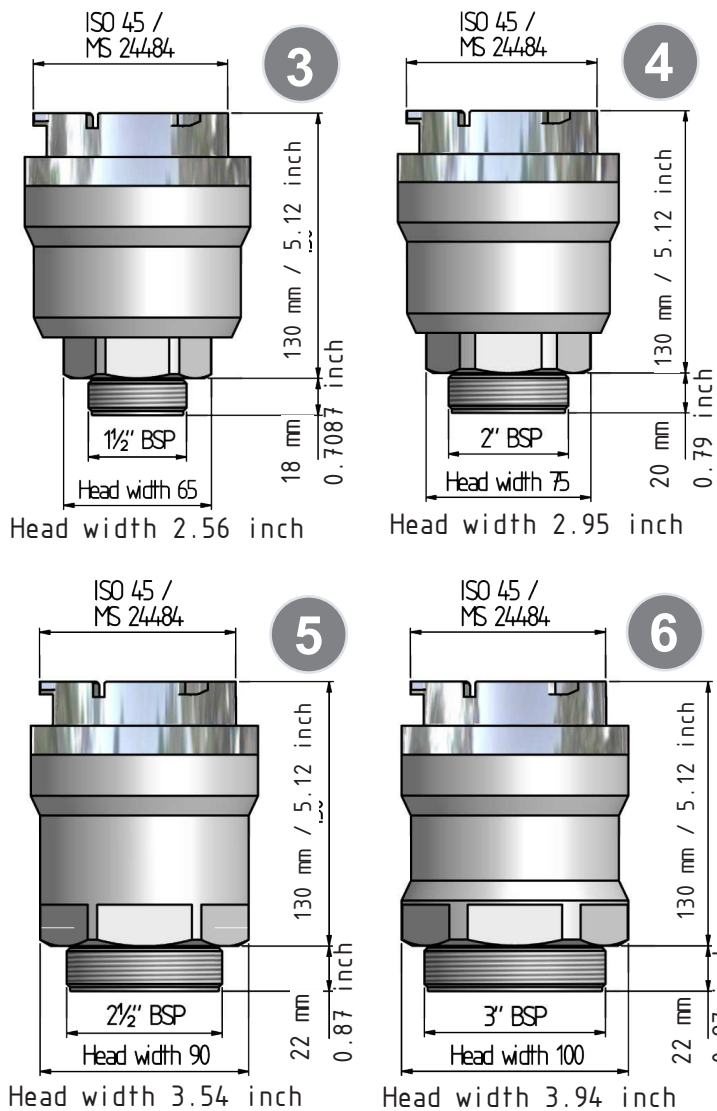

| Connection | Material | Weight | Code No |
|--------------|----------|------------------|------------|
| 1 1 1/2" BSP | AL | 2.1 kg / 4.6 lbs | G375A1401B |
| 1 2" BSP | | 2.2 kg / 4.8 lbs | G378A1401B |
| 2 2 1/2" BSP | | 2.2 kg / 4.8 lbs | G380A1401B |
| 2 3" BSP | | 2.3 kg / 5.1 lbs | G382A1401B |
| 1 1/2" BSP | SS | - | G375A4401B |
| 2" BSP | | - | G378A4401B |
| 2 1/2" BSP | | - | G380A4401B |
| 3" BSP | | - | G382A4401B |

| Working pressure: | Test pressure: |
|-------------------|------------------|
| 10 bar / 150 psi | 15 bar / 225 psi |
| Threads: | |
| BSP = ISO 228, | NPT = B1.20.1 |

No part of this leaflet may be reproduced in any form or by any means without permission in writing from the publisher.

Tank unit (Ground unit) with standard flange, 2½" ASA 150 psi

Body material in aluminium and stainless steel.

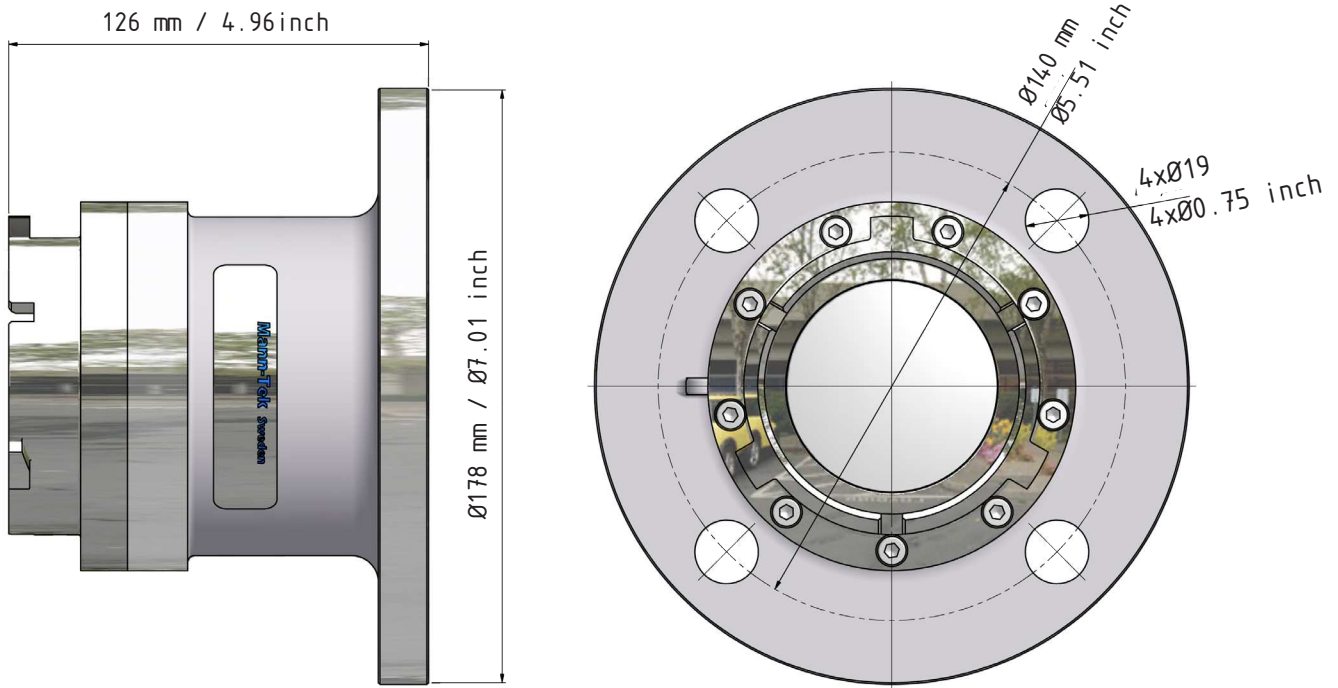

| Flange | Material (Body) | Weight | Code No |
|-----------------|-----------------|------------------|-----------|
| 2½" ASA 150 psi | AL | 2.7 kg / 6.0 lbs | G359D1401 |
| 2½" ASA 150 psi | SS | - | G359B4401 |

Tank unit (Ground unit) with standard flange, 3" ASA 150 psi

Body material in aluminium and stainless steel.

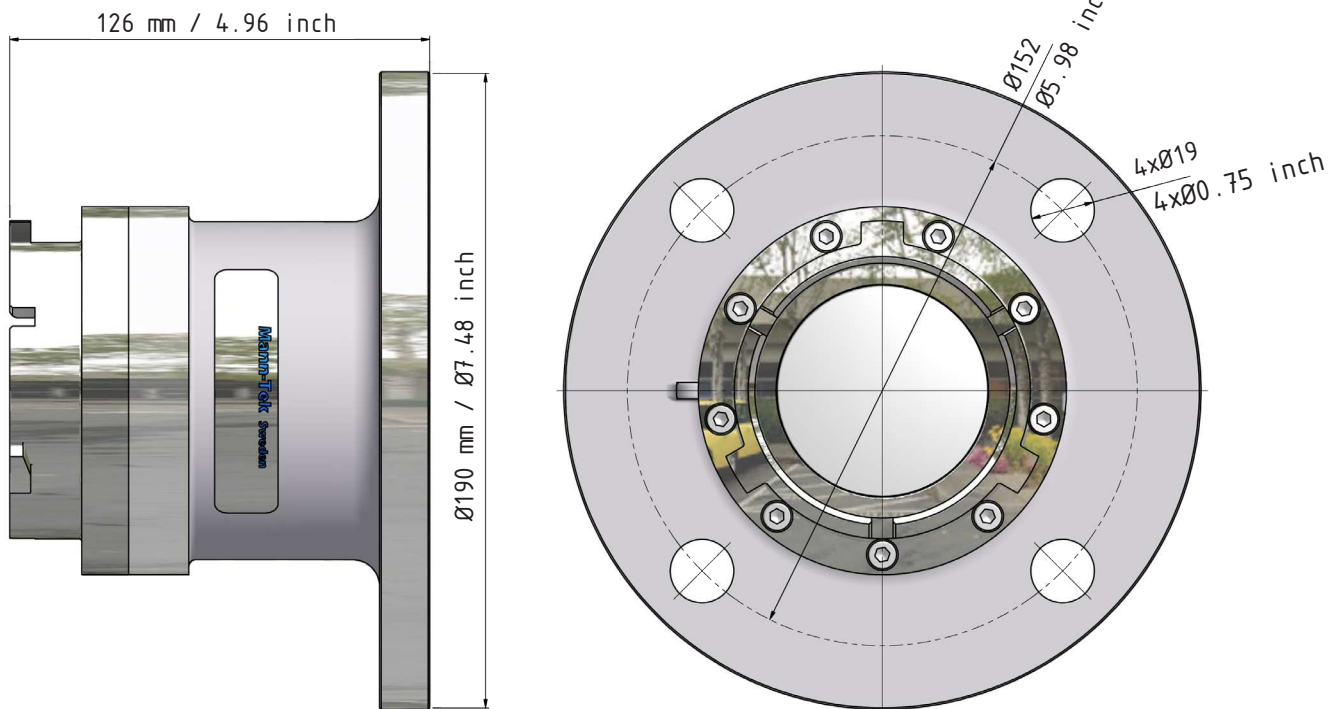

| Flange | Material (Body) | Weight | Code No |
|----------------|-----------------|------------------|-----------|
| 3" ASA 150 psi | AL | 2.9 kg / 6.4 lbs | G361D1401 |
| 3" ASA 150 psi | SS | - | G361B4401 |

Tank unit (Ground unit) with standard flange, DIN DN 65 PN 10/16

Body material in aluminium and stainless steel.

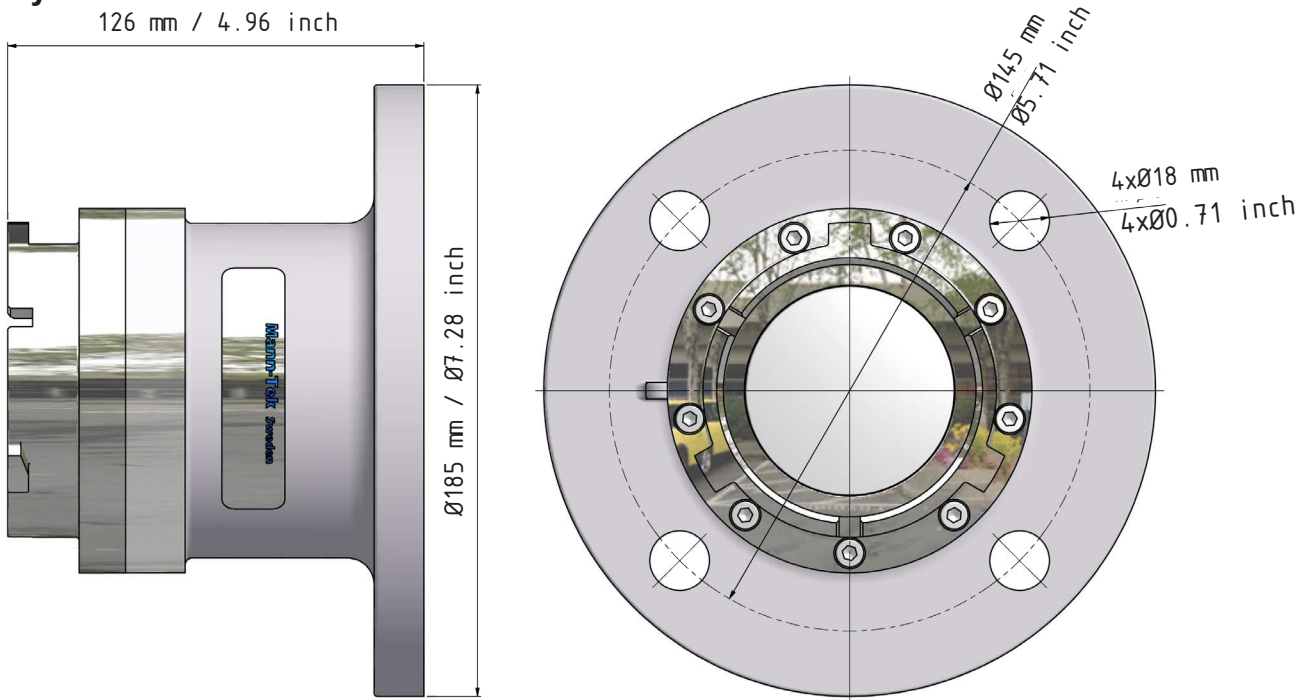

| Flange | Material (Body) | Weight | Code No |
|----------------|-----------------|----------------|-----------|
| DN 65 PN 10/16 | AL | 2.8 kg 6.2 lbs | G333D1401 |
| DN 65 PN 10/16 | SS | - | G333B4401 |

Tank unit (Ground unit) with standard flange, DIN DN 80 PN 10/16

Body material in aluminium and stainless steel.

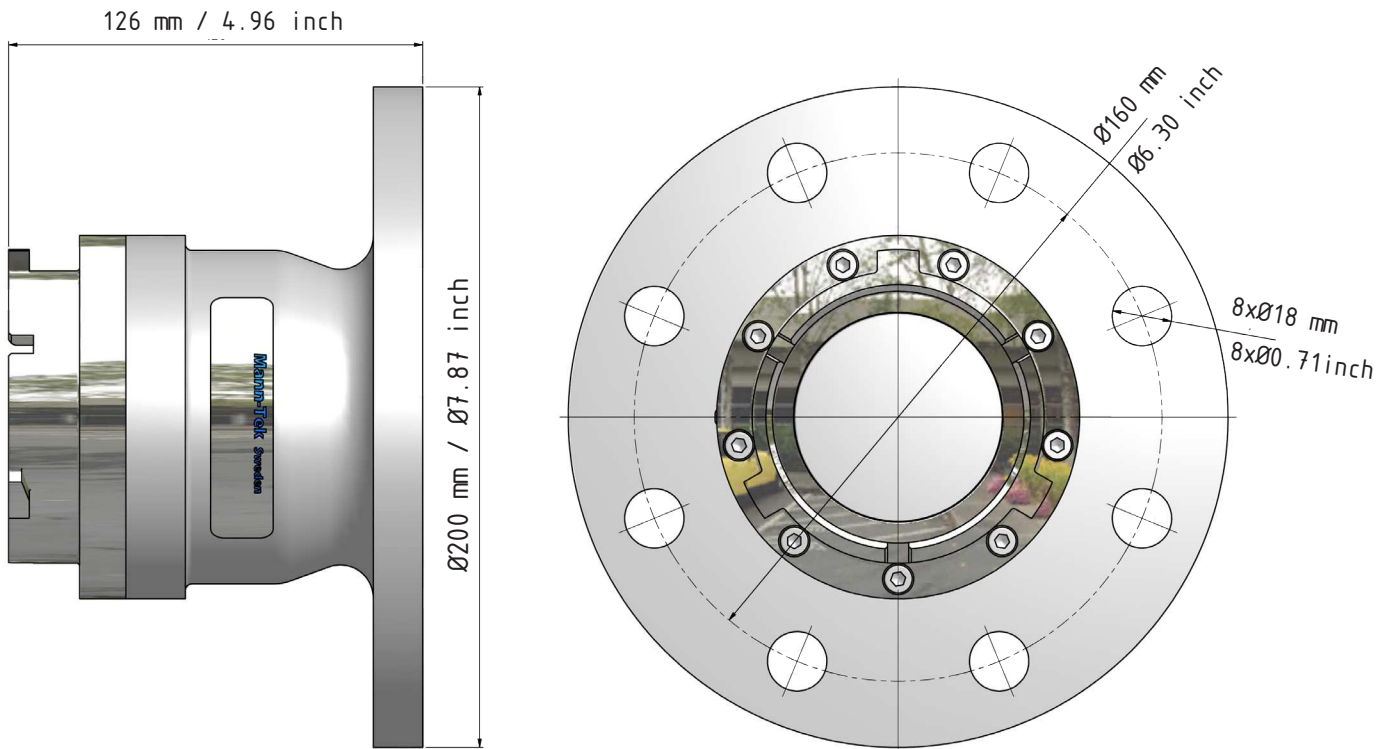

| Flange | Material (Body) | Weight | Code No |
|----------------|-----------------|------------------|-----------|
| DN 80 PN 10/16 | AL | 3.0 kg / 6.6 lbs | G336D1401 |
| DN 80 PN 10/16 | SS | - | G336B4401 |

No part of this leaflet may be reproduced in any form or by any means without permission in writing from the publisher.

Tank unit (Ground unit) with standard flange, TW1 (DIN 28459)

Body material in aluminium and stainless steel.

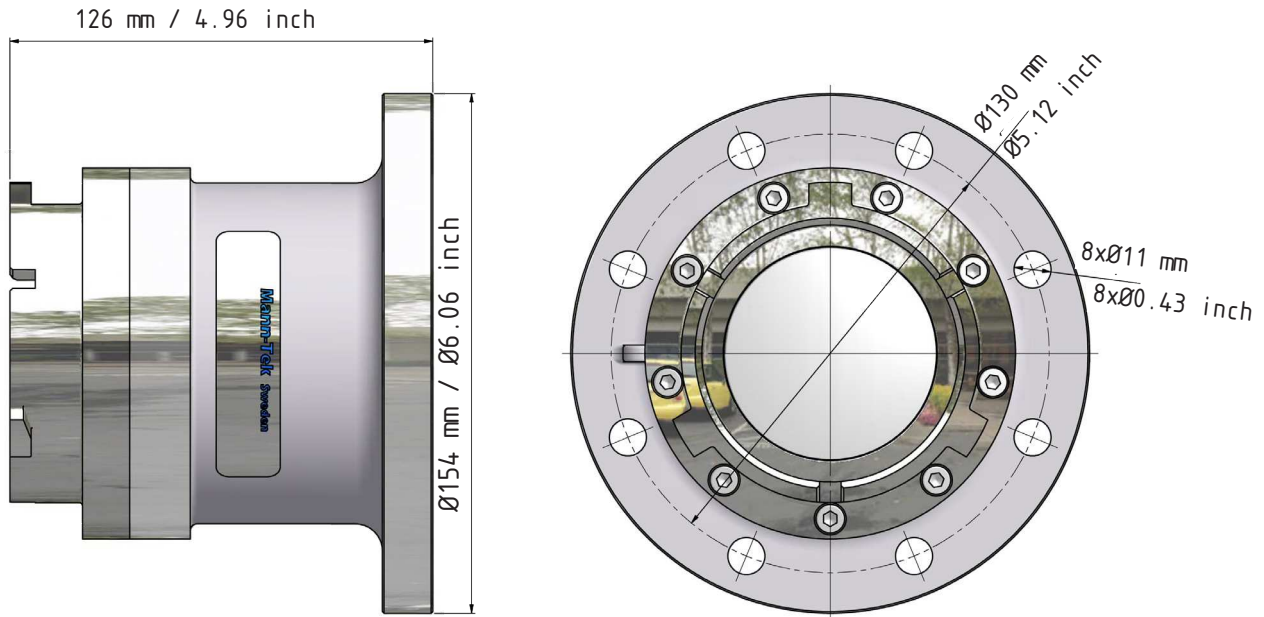

| Flange | Material (Body) | Weight | Code No |
|-----------------|-----------------|------------------|-----------|
| TW1 (DIN 28459) | AL | 2.5 kg / 5.5 lbs | G365D1401 |
| TW1 (DIN 28459) | SS | - | G365B4401 |

Tank unit (Ground unit) with standard flange, TW3 (DIN 28459)

Body material in aluminium and stainless steel.

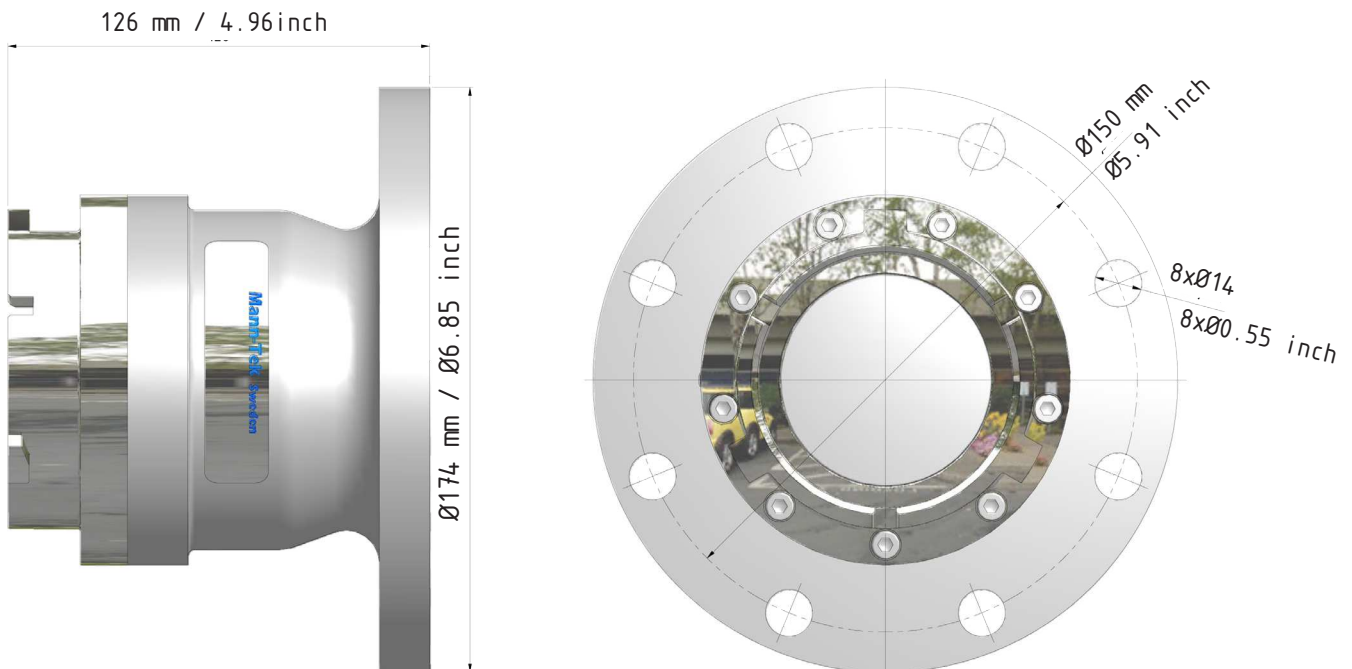

| Flange | Material (Body) | Weight | Code No |
|-----------------|-----------------|------------------|-----------|
| TW3 (DIN 28459) | AL | 2.9 kg / 6.4 lbs | G366D1401 |
| TW3 (DIN 28459) | SS | - | G366B4401 |

Tank unit (Ground unit) with standard flange, 3" TTMA

Body material in aluminium and stainless steel.

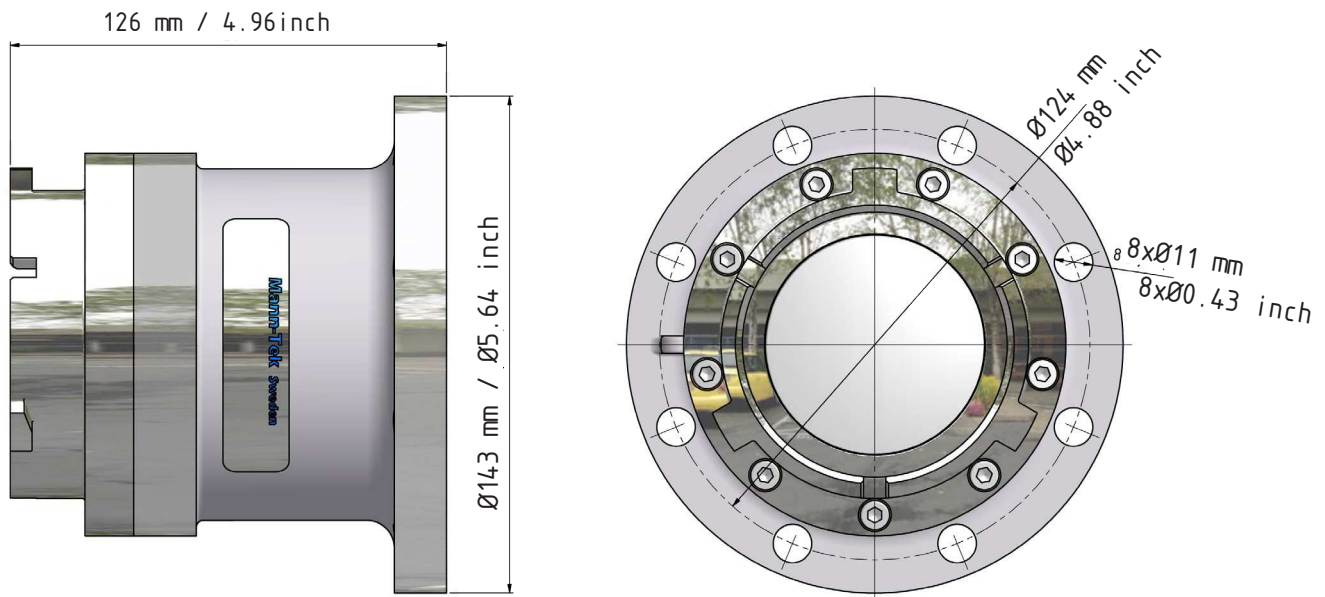

| Flange | Material (Body) | Weight | Code No |
|---------|-----------------|------------------|-----------|
| 3" TTMA | AL | 2.4 kg / 5.3 lbs | G367D1401 |
| 3" TTMA | SS | - | G367B4401 |

Tank unit (Ground unit) with standard flange, 4" TTMA

Body material in aluminium and stainless steel.

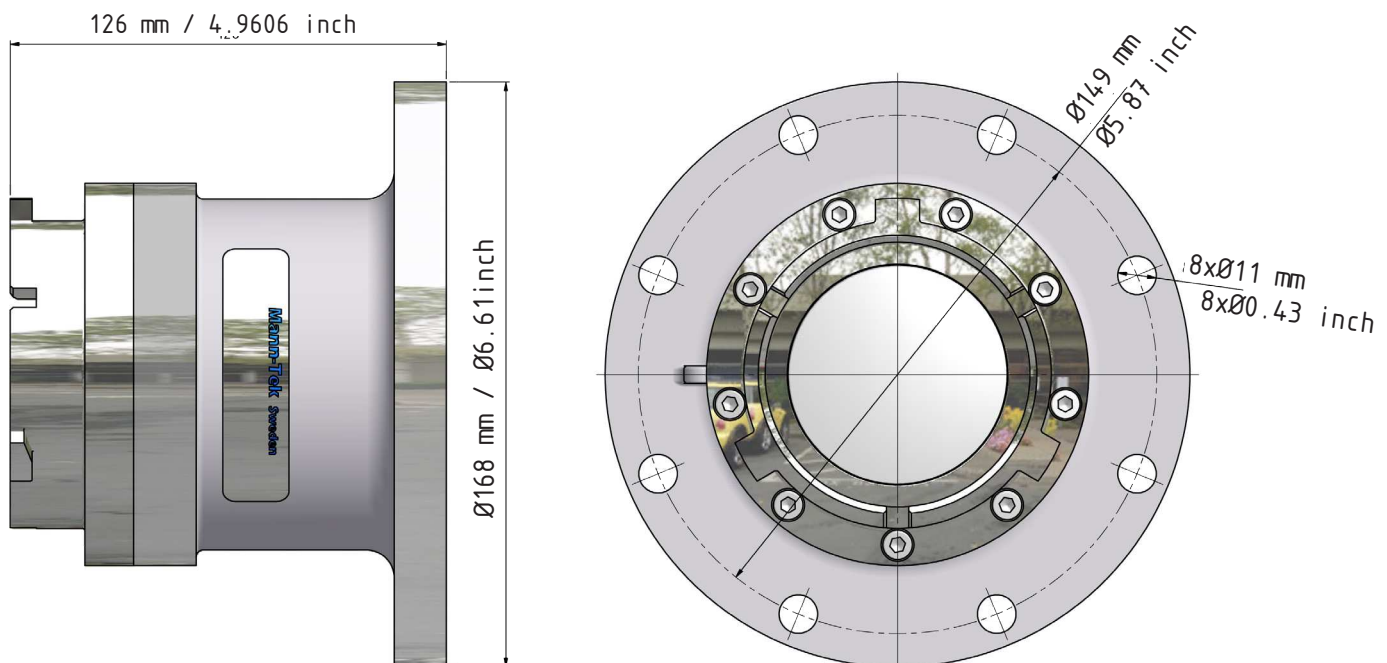

| Flange | Material (Body) | Weight | Code No |
|---------|-----------------|------------------|-----------|
| 4" TTMA | AL | 2.6 kg / 5.7 lbs | G368D1401 |
| 4" TTMA | SS | - | G368B4401 |

No part of this leaflet may be reproduced in any form or by any means without permission in writing from the publisher.

Tank unit (Ground unit) with square flange 120 mm

Body material in aluminium and stainless steel.

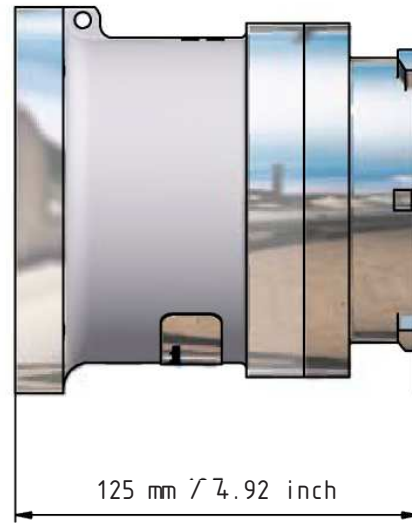
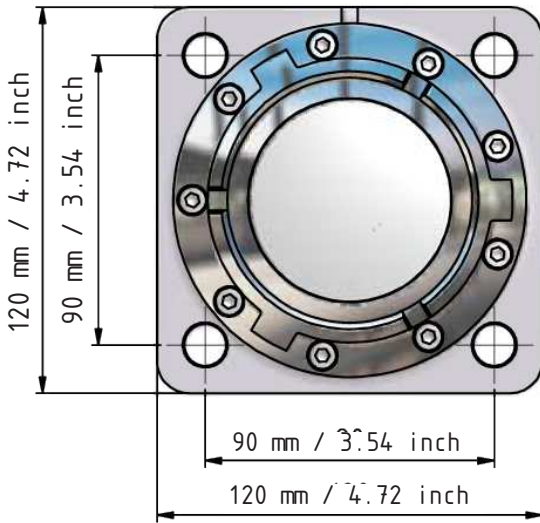

| Flange | Material (Body) | Weight | Code No |
|-----------------------------------|-----------------|------------------|------------|
| Square flange, 120 mm / 4.72 inch | AL | 2.7 kg / 6.0 lbs | G3107D1401 |
| Square flange, 120 mm / 4.72 inch | SS | - | G3107B4401 |

Drain Connection

Option Drain connection

Use Mann-Tek ISO45 with Drain connection for easy draining and sampling of your system.

Available in all Tank units with flange

Drain connection: 3/8" (thread standard)

Other threads on request.

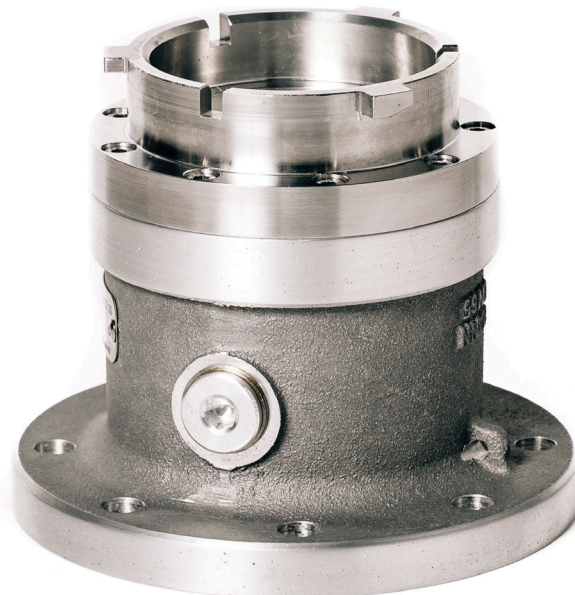

How to Order: Code nr. + D-G3-11-C1

No part of this leaflet may be reproduced in any form or by any means without permission in writing from the publisher.

Dust plug and cap



Dust Cap (for Tank Unit)

| Code nr: | Material: | Weight: |
|-----------|-------------------------|-------------------|
| K300A1101 | Aluminium | 0,5 kg / 1.10 lbs |
| K300A2201 | Composite ¹⁾ | 0.2 kg / 0,44 lbs |

A dust cap should be used to prevent the ingress of dirt or water.

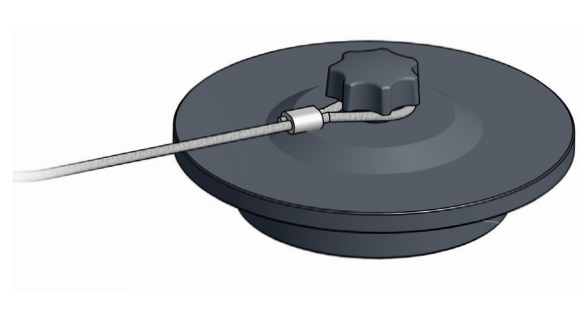

Dust Plug (for HoseUnit)

| Code nr: | Material: | Weight: |
|-----------|-------------------------|-------------------|
| I300A1101 | Aluminium | 0,4 kg / 0.88 lbs |
| I300A2201 | Composite ¹⁾ | 0.2 kg / 0.44 lbs |

A dust cap should be used to prevent the ingress of dirt or water.

¹⁾ Lowest operation temperature is -20° C / -4° F

Technical Data

Size of ISO45 DACoupling: 2½" (DN 65)

Materials: Aluminium

Seals: FPM (Viton*) or NBR (Nitrile) , Low temperature NBR, FQM (Flourosilicon)

*) Viton is a registered trademark of DuPoint

Lowest Operation Temperature :

| With Seals Material: | Lowest Temperature: |
|----------------------|---------------------|
| FPM (Standard Viton) | -20° C / -4° F |
| NBR | -25° C / -13° F |
| Low temperature NBR | -40° C / -40° F |
| FQM (Flourosilicon) | -55° C / -67° F |

These materials must be tried individually and are subject to no obligation. Always check with chemical compability chart before use.

Max Working Pressure: 10 bar (150 psi)

Test Pressure: 15 bar (225 psi)

Min. Burst Pressure: 50 bar (750 psi)

Safety Factor: 5:1

End Connections: BSP- and NPT-threads, DIN- and ASA-flanges. Other connections on request.

No part of this leaflet may be reproduced in any form or by any means without permission in writing from the publisher.

No part of this leaflet may be reproduced in any form or by any means without permission in writing from the publisher.

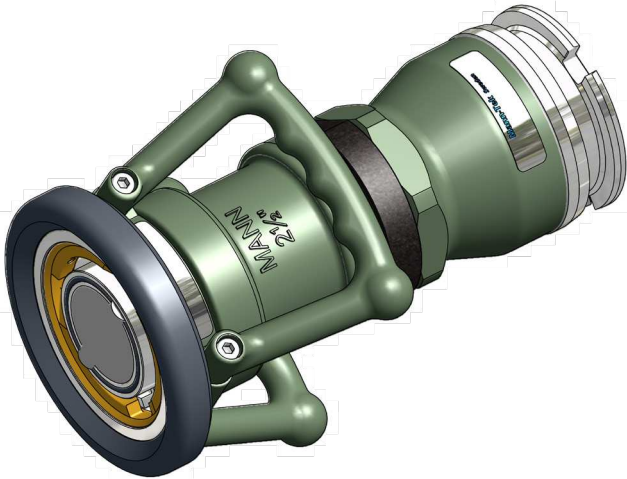

2½" ISO45 Hose Unit to Tank Unit 3" (119 mm)¹⁾ STANAG 3756



3" (119 mm)¹⁾ Tank Unit STANAG 3756 to 2½" (105 mm)¹⁾ Hose unit



The ISO45 coupling, in green colour, are also used for Military purposes with different adaptor systems.

Connection adaptor:

- 2½" ISO45 to 3" (119 mm)¹⁾ Tank Unit STANAG 3756.
- 2½" ISO45 to 3" (119 mm)¹⁾ TW EN14420-5
- 3" (119 mm)¹⁾ Hose Unit / Tank Unit STANAG 3756 to 3" (119 mm)¹⁾ TW EN14420- 5 Hose Unit / Tank Unit
- 3" (119 mm)¹⁾ Tank Unit STANAG 3756 to 2½" (105 mm)¹⁾ Hose Unit

The ISO45 Tank Unit are also available with pressure equalizing valve and pressure relief valve.

¹⁾ Connection 119 mm = 4.68 inch and 105 mm = 4.13 inch

Examples of Military RAL colours



RAL 6014
Yellow Olive
- Dutch Army



RAL 6031
Bronze Green
-Dutch, Germany, Denmark, Spain, Italy and Sweden.



RAL 8027
Leather Brown
- Germany



RAL 9021
Tar Black
- Germany

Other colours on request

We can not guarantee that the colours above are correctly illustrated because print quality

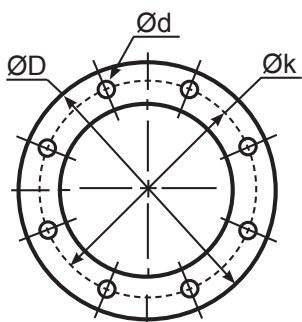

- Ø D = Diameter
- Ø k = Centre diameter
- n = Numer of holes
- Ø d = Hole diameter

| EN 1092-1 | | | | | | | | | | | | | | | | | |
|-----------|-------|-------|-------|----|-------|-------|-------|----|-------|-------|-------|----|-------|-------|-------|----|------|
| DN | PN 10 | | | | PN 16 | | | | PN 25 | | | | PN 40 | | | | |
| | | ØD | Øk | n | Ød | ØD | Øk | n | Ød | ØD | Øk | n | Ød | ØD | Øk | n | Ød |
| 20 | mm | 105 | 75 | 4 | 14 | 105 | 75 | 4 | 14 | 105 | 75 | 4 | 14 | 105 | 75 | 4 | 14 |
| | inch | 4.13 | 2.95 | | 0.55 | 4.13 | 2.95 | | 0.55 | 4.13 | 2.95 | | 0.55 | 4.13 | 2.95 | | 0.55 |
| 25 | mm | 115 | 85 | 4 | 14 | 115 | 85 | 4 | 14 | 115 | 85 | 4 | 14 | 115 | 85 | 4 | 14 |
| | inch | 4.53 | 3.35 | | 0.55 | 4.53 | 3.35 | | 0.55 | 4.53 | 3.35 | | 0.55 | 4.53 | 3.35 | | 0.55 |
| 32 | mm | 140 | 100 | 4 | 18 | 140 | 100 | 4 | 18 | 140 | 100 | 4 | 18 | 140 | 100 | 4 | 18 |
| | inch | 5.51 | 3.94 | | 0.71 | 5.51 | 3.94 | | 0.71 | 5.51 | 3.94 | | 0.71 | 5.51 | 3.94 | | 0.71 |
| 40 | mm | 150 | 110 | 4 | 18 | 150 | 110 | 4 | 18 | 150 | 110 | 4 | 18 | 150 | 110 | 4 | 18 |
| | inch | 5.91 | 4.33 | | 0.71 | 5.91 | 4.33 | | 0.71 | 5.91 | 4.33 | | 0.71 | 5.91 | 4.33 | | 0.71 |
| 50 | mm | 165 | 125 | 4 | 18 | 165 | 125 | 4 | 18 | 165 | 125 | 4 | 18 | 165 | 125 | 4 | 18 |
| | inch | 6.50 | 4.92 | | 0.71 | 6.50 | 4.92 | | 0.71 | 6.50 | 4.92 | | 0.71 | 6.50 | 4.92 | | 0.71 |
| 65 | mm | 185 | 145 | 4 | 18 | 185 | 145 | 4 | 18 | 185 | 145 | 8 | 18 | 185 | 145 | 8 | 18 |
| | inch | 7.28 | 5.71 | | 0.71 | 7.28 | 5.71 | | 0.71 | 7.28 | 5.71 | | 0.71 | 7.28 | 5.71 | | 0.71 |
| 80 | mm | 200 | 160 | 8 | 18 | 200 | 160 | 8 | 18 | 200 | 160 | 8 | 18 | 200 | 160 | 8 | 18 |
| | inch | 7.87 | 6.30 | | 0.71 | 7.87 | 6.30 | | 0.71 | 7.87 | 6.30 | | 0.71 | 7.87 | 6.30 | | 0.71 |
| 100 | mm | 220 | 180 | 8 | 18 | 220 | 180 | 8 | 18 | 235 | 190 | 8 | 22 | 235 | 190 | 8 | 22 |
| | inch | 8.66 | 7.09 | | 0.71 | 8.66 | 7.09 | | 0.71 | 9.25 | 7.48 | | 0.87 | 9.25 | 7.48 | | 0.87 |
| 125 | mm | 250 | 210 | 8 | 18 | 250 | 210 | 8 | 18 | 270 | 220 | 8 | 26 | 270 | 220 | 8 | 26 |
| | inch | 9.84 | 8.27 | | 0.71 | 9.84 | 8.27 | | 0.71 | 10.63 | 8.66 | | 1.02 | 10.63 | 8.66 | | 1.02 |
| 150 | mm | 285 | 240 | 8 | 22 | 285 | 240 | 8 | 22 | 300 | 250 | 8 | 26 | 300 | 250 | 8 | 26 |
| | inch | 11.22 | 9.45 | | 0.87 | 11.22 | 9.45 | | 0.87 | 11.81 | 9.84 | | 1.02 | 11.81 | 9.84 | | 1.02 |
| 200 | mm | 340 | 295 | 8 | 22 | 340 | 295 | 12 | 22 | 360 | 310 | 12 | 26 | 375 | 320 | 12 | 30 |
| | inch | 13.39 | 11.61 | | 0.87 | 13.39 | 11.61 | | 0.87 | 14.17 | 12.20 | | 1.02 | 14.76 | 12.60 | | 1.18 |
| 250 | mm | 395 | 355 | 12 | 22 | 405 | 355 | 12 | 26 | 425 | 370 | 12 | 30 | 450 | 385 | 12 | 33 |
| | inch | 15.55 | 13.98 | | 0.87 | 15.94 | 13.98 | | 1.02 | 16.73 | 14.57 | | 1.18 | 17.72 | 15.16 | | 1.30 |
| 300 | mm | 445 | 400 | 12 | 22 | 460 | 410 | 12 | 26 | 485 | 430 | 16 | 30 | 515 | 450 | 16 | 33 |
| | inch | 17.52 | 15.75 | | 0.87 | 18.11 | 16.14 | | 1.02 | 19.09 | 16.93 | | 1.18 | 20.28 | 17.65 | | 1.30 |

Flange translation EN 1092 ---- DIN

| EN 1092-1 | DIN |
|------------------------------|-----------------|
| EN 1092-1 PN 6 | DIN 2631 |
| EN 1092-1 PN 10 | DIN 2632 |
| EN 1092-1 PN 16 | DIN 2633 |
| EN 1092-1 PN 25 | DIN 2634 |
| EN 1092-1 PN 40 | DIN 2635 |
| EN 1092-1 Type B Raised Face | DIN 2526 Form C |
| EN 1092-1 Type C Tongue | DIN 2512 Form F |
| EN 1092-1 Type D Groove | DIN 2512 Form N |
| EN 1092-1 Type E Spigot | DIN 2513 Form V |
| EN 1092-1 Type F Recess | DIN 2513 Form R |

Flange Measurement - 2/2

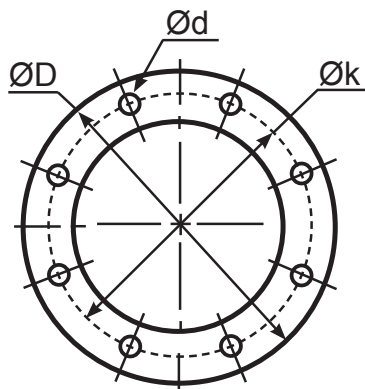

- Ø D = Diameter
- Ø k = Centre diameter
- n = Number of holes
- Ø d = Hole diameter

No part of this leaflet may be reproduced in any form or by any means without permission in writing from the publisher.

| ANSI (ASA) B 16,5 | | | | | | | | | |
|-------------------|------|---------|--------|----|------|---------|--------|----|-------|
| INCH | | 150 psi | | | | 300 psi | | | |
| | | ØD | Øk | n | Ød | ØD | Øk | n | Ød |
| 3/4" | mm | 98,4 | 69,8 | 4 | 15,9 | 117,5 | 82,5 | 4 | 19 |
| | inch | 3 7/8 | 2 3/4 | | 5/8 | 4 5/8 | 3 1/4 | | 3/4 |
| 1" | mm | 107,7 | 79,4 | 4 | 15,9 | 123,8 | 88,9 | 4 | 19 |
| | inch | 4 1/4 | 3 1/8 | | 5/8 | 4 7/8 | 3 1/2 | | 3/4 |
| 1 1/4" | mm | 117,5 | 88,9 | 4 | 15,9 | 133,3 | 98,4 | 4 | 19 |
| | inch | 4 5/8 | 3 1/2 | | 5/8 | 5 1/4 | 3 7/8 | | 3/4 |
| 1 1/2" | mm | 127 | 98,4 | 4 | 15,9 | 155,6 | 114,3 | 4 | 22,2 |
| | inch | 5 | 3 7/8 | | 5/8 | 6 1/8 | 4 1/2 | | 7/8 |
| 2" | mm | 152,4 | 120,6 | 4 | 19 | 165,1 | 127 | 8 | 19 |
| | inch | 6 | 4 3/4 | | 3/4 | 6 1/2 | 5 | | 3/4 |
| 2 1/2" | mm | 177,8 | 139,7 | 4 | 19 | 190,5 | 149,2 | 8 | 22,2 |
| | inch | 7 | 5 1/2 | | 3/4 | 7 1/2 | 5 7/8 | | 7/8 |
| 3" | mm | 190,5 | 152,4 | 4 | 19 | 209,5 | 168,3 | 8 | 22,2 |
| | inch | 7 1/2 | 6 | | 3/4 | 8 1/4 | 6 5/8 | | 7/8 |
| 4" | mm | 228,5 | 190,5 | 8 | 19 | 254 | 200 | 8 | 22,2 |
| | inch | 9 | 7 1/2 | | 3/4 | 10 | 7 7/8 | | 7/8 |
| 5" | mm | 254 | 215,9 | 8 | 22,2 | 279,4 | 234,9 | 8 | 22,2 |
| | inch | 10 | 8 1/2 | | 7/8 | 11 | 9 1/4 | | 7/8 |
| 6" | mm | 279,4 | 241,3 | 8 | 22,2 | 317,5 | 269,9 | 12 | 22,2 |
| | inch | 11 | 9 1/2 | | 7/8 | 12 1/2 | 10 5/8 | | 7/8 |
| 8" | mm | 342,9 | 298,4 | 8 | 22,2 | 381 | 330,2 | 12 | 25,4 |
| | inch | 13 1/2 | 11 3/4 | | 7/8 | 15 | 13 | | 1 |
| 10" | mm | 406,4 | 361,9 | 12 | 25,4 | 444,5 | 387,3 | 16 | 28,6 |
| | inch | 16 | 14 1/4 | | 1 | 17 1/2 | 15 1/4 | | 1 1/8 |
| 12" | mm | 482,6 | 431,8 | 12 | 25,4 | 520,7 | 450,8 | 16 | 31,7 |
| | inch | 19 | 17 | | 1 | 20 1/2 | 17 3/4 | | 1 1/4 |

| TW DIN 28459 | | | | | | |
|--------------|-----|------|------|------|----|------|
| | DN | ØD | Øk | n | Ød | |
| TW1 | 50 | mm | 154 | 130 | 8 | 11 |
| | | inch | 6.06 | 5.12 | | 0.43 |
| TW1 | 80 | mm | 154 | 130 | 8 | 11 |
| | | inch | 6.06 | 5.12 | | 0.43 |
| TW3 | 100 | mm | 174 | 150 | 8 | 14 |
| | | inch | 6.85 | 5.91 | | 0.55 |
| TW5 | 125 | mm | 204 | 176 | 8 | 14 |
| | | inch | 8.03 | 6.93 | | 0.55 |
| TW7 | 150 | mm | 240 | 210 | 12 | 14 |
| | | inch | 9.45 | 8.27 | | 0.55 |

| T.T.M.A | | | | | |
|---------|------|-------|-------|----|------|
| INCH | | ØD | Øk | n | Ød |
| 2" | mm | 114,3 | 95,3 | 6 | 11,1 |
| | inch | 4.50 | 3.75 | | 0.44 |
| 3" | mm | 142,9 | 123,8 | 8 | 11,1 |
| | inch | 5.63 | 4.87 | | 0.44 |
| 4" | mm | 168,3 | 149,2 | 8 | 11,1 |
| | inch | 6.63 | 5.87 | | 0.44 |
| 5" | mm | 196,9 | 177,8 | 12 | 11,1 |
| | inch | 7.75 | 7.00 | | 0.44 |
| 6" | mm | 228,6 | 206,4 | 12 | 11,1 |
| | inch | 9.00 | 8.13 | | 0.44 |
| 8" | mm | 276,2 | 257,2 | 16 | 11,1 |
| | inch | 10.87 | 10.13 | | 0.44 |

Mounting instruction

When installing Mann Tek equipment to new pipe work, tanks, etc. ensure the system is free from debris that may be transferred through the coupling. Where the hose or loading arm assembly is the primary static dissipation or earth route, the electrical continuity value of the assembly shall be checked to ensure regulatory compliance. Special attention should be paid to the balancing of loading arms. The weight of the coupling plus transfer media should be taken into account at the specification stage. It is usual for loading arm balance settings to account of weight variations due to differences in the full / empty cycle.

The loading arm should be set to balance in the condition present at the time of connection. For example, should the loading arm be empty at the time of connection then it should be balanced in the empty condition.

The Mann-Tek product can be installed directly in the product line and is ready for use after removing the transport protection. The installation is recommended as follows:

- Remove the packaging and the flange protection
- Check the coupling for damages before mounting.
- To prevent damages during mounting a suitable wrench should be used for the intended bolts and nuts.
- Ensure that the product line is empty and all valves are close before you connect the coupling into the line.
- Set in all bolts first and tighten them by hand. Then increase the tightening torque in 2 steps up to the recommended value in the following table. Proceed every time according to the sequence shown in g.
- Tightening torque¹⁾ for bolts:

| Metric | |
|--------|--------|
| Size | 8.8 |
| M8 | 24 Nm |
| M10 | 50 Nm |
| M12 | 85 Nm |
| M16 | 210 Nm |
| M20 | 410 Nm |
| M22 | 550 Nm |
| M24 | 700 Nm |

| Inch | |
|--------------|------------|
| Size | A193 B7 |
| 5/16 -18 UNC | 16 lbf-ft |
| 3/8 -16 UNC | 29 lbf-ft |
| 1/2 -13 UNC | 70 lbf-ft |
| 5/8 -11 UNC | 139 lbf-ft |
| 3/4 -10 UNC | 243 lbf-ft |
| 7/8 -9 UNC | 389 lbf-ft |
| 1 -8 UNC | 582 lbf-ft |

- Bolt tightening sequence.

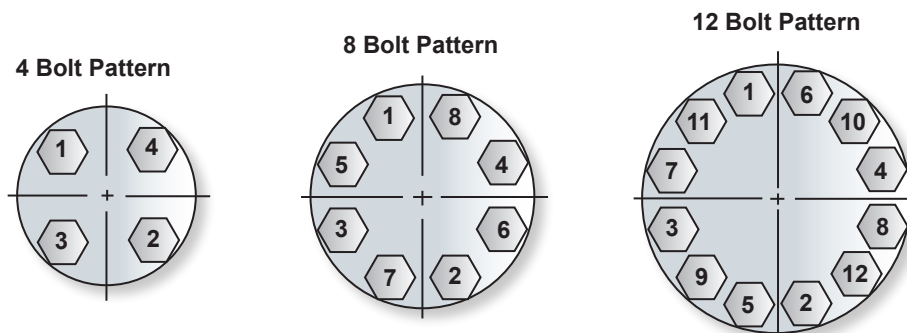

The start-up may take place only when the Mann-Tek product has been mounted as instructed and the necessary function tests and leak tests have been conducted by the approved authorities.

¹⁾ The torque forces recommended bases on a thread friction coefficient $\mu=0,14$ and a standard flat seal according to EN 1514-1

NPT

Sealing NPT threads can be an exasperating experience if certain techniques are not followed. The following tips will help alleviate many common problems in thread sealing:

1. Always use some type of sealant (tape or paste) and apply sealant to male thread only. If using a hydraulic sealant, allow sufficient curing time before system is pressurized.
2. When using tape sealant, wrap the threads in a clock-wise motion starting at the first thread and, as layers are applied, work towards the imperfect (vanishing) thread. If the system that the connection being made to cannot tolerate foreign matter (i.e. air systems), leave the first thread exposed and apply the tape sealant as outlined above.
3. When using paste sealant, apply to threads with a brush, using the brush to work the sealant into the threads. Apply enough sealant to fill in all the threads all the way around.
4. When connecting one stainless steel part to another stainless steel part that will require future disassembly, use a thread sealant that is designed for stainless steel. This stainless steel thread sealant is also useful when connecting aluminium to aluminium that needs to be disconnected in the future. These two materials gall easily, and if the correct sealant is not used, it can be next to impossible to disassemble.
5. When connecting parts made of dissimilar metals (i.e. steel and aluminium), standard tape or paste sealant performs satisfactory.
6. For sizes 2" and below, tape or paste performs satisfactory. When using thread tape, four wraps (covering all necessary threads) is usually sufficient.
7. For sizes 2½" and above, thread paste is recommended. If thread tape is used, eight wraps (covering all necessary threads) is usually sufficient. Apply more wraps if necessary.
8. For stubborn to seal threads, apply a normal coating of thread paste followed by a normal layer of thread tape.
9. For extremely stubborn to seal threads, apply a normal coating of thread paste followed by a single layer of gauze bandage followed by a normal layer of thread tape.

Caution!

When this procedure is done, the connection becomes permanent. Extreme measures will be necessary to disconnect these components. All other measures to seal the threads should be explored prior to use of this technique.

10. Over-tightening threads can be just as detrimental as insufficient tightening. For sizes 2" and below, hand tighten the components and, with a wrench, tighten 3 full turns. For sizes 2½" and above, hand tighten the components and, with a wrench, tighten 2 full turns.

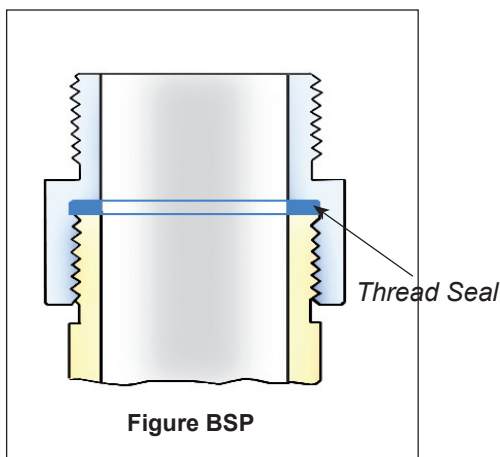
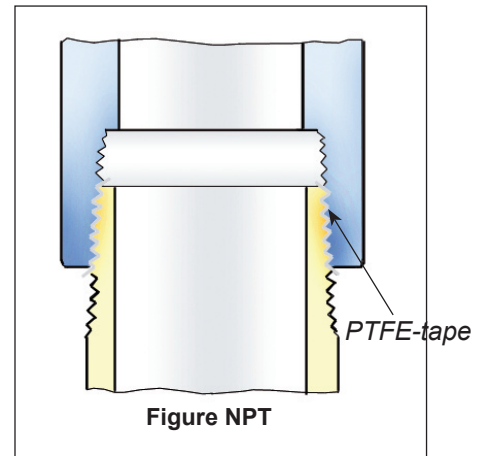

BSP

The threads are parallel with flat sealing surface. This allows to use the full thread length for screwed-on parts. The largest possible transfer of force is guaranteed for short length. The thread seal behind the relief groove of the thread cannot drop out.

Simple screwing down, makes a safe connection. Subsequent tightening during operation is possible at any time. Change of seal and new assembly do not require any expert knowledge.

The European standardisations for hose assemblies require parallel threads with flat seals, because of the advantages.

Flat Seals for thread - 1/2

| weight ≈kg | Thread BSP | Materials Application | Dimensions ≈ mm | | | Product No |
|---------------|---------------|--|--------------------|-----|-----|---------------|
| | | | D | d | s | |
| 0,001 | BSP 1/2" | PTFE (Teflon®) white , massive continuously hard, universally resistant Teflon® is a registered trademark of DuPont | 20 | 13 | 2 | On request |
| 0,001 | BSP 3/4" | | 26 | 19 | 2 | 1498-06 |
| 0,002 | BSP 1" | | 33 | 24 | 2 | 1220-06 |
| 0,003 | BSP 1 1/4" | | 42 | 34 | 2 | 1536-06 |
| 0,003 | BSP 1 1/2" | | 48 | 39 | 2 | 1196-06 |
| 0,004 | BSP 2" | | 60 | 49 | 2 | 1052-06 |
| 0,007 | BSP 2 1/2" | | 76 | 63 | 2,5 | 1181-06 |
| 0,006 | BSP 3" | | 88 | 77 | 3 | 1110-06 |
| 0,009 | BSP 4" | | 114 | 100 | 3 | 1295-06 |
| 0,016 | BSP 6" | | 164 | 150 | 3 | 1963-06 |
| 0,001 | BSP 1/2" | Thermopac asbestos free, light hard. Especially for hot oils and hot bitumen up to 250° C and for hot water and saturated steam up to 25 bar. | 20 | 13 | 2 | On request |
| 0,001 | BSP 3/4" | | 26 | 19 | 2 | 1498-25 |
| 0,002 | BSP 1" | | 33 | 24 | 2 | 1220-25 |
| 0,002 | BSP 1 1/4" | | 42 | 34 | 2 | 1536-25 |
| 0,003 | BSP 1 1/2" | | 48 | 39 | 2 | 1196-25 |
| 0,004 | BSP 2" | | 60 | 49 | 2 | 1052-25 |
| 0,005 | BSP 2 1/2" | | 76 | 63 | 3 | 1181-25 |
| 0,009 | BSP 3" | | 88 | 77 | 3 | 1110-25 |
| 0,013 | BSP 4" | | 114 | 100 | 3 | 1295-25 |
| 0,016 | BSP 6" | | 164 | 150 | 3 | 1963-25 |
| 0,001 | BSP 1/2" | FPM/FKM (Viton®) soft for aromatic hydrocarbons and hot oils. Viton® is a registered trademark of DuPont | 20 | 13 | 2 | On request |
| 0,001 | BSP 3/4" | | 26 | 19 | 2 | 1498-01 |
| 0,002 | BSP 1" | | 33 | 24 | 2 | 1220-01 |
| 0,002 | BSP 1 1/4" | | 42 | 34 | 2 | 1536-01 |
| 0,003 | BSP 1 1/2" | | 48 | 39 | 2 | 1196-01 |
| 0,004 | BSP 2" | | 60 | 49 | 2 | 1052-01 |
| 0,006 | BSP 2 1/2" | | 76 | 63 | 3 | 1181-01 |
| 0,008 | BSP 3" | | 88 | 77 | 3 | 1110-01 |
| 0,014 | BSP 4" | | 114 | 100 | 3 | 1295-01 |
| 0,016 | BSP 6" | | 164 | 150 | 3 | 1963-01 |

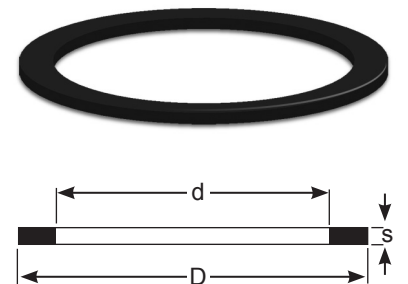
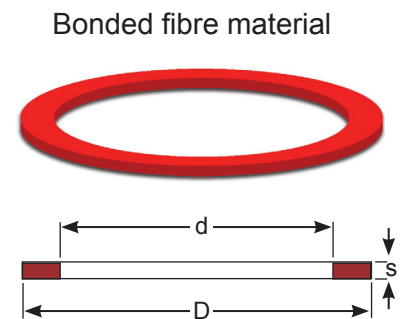
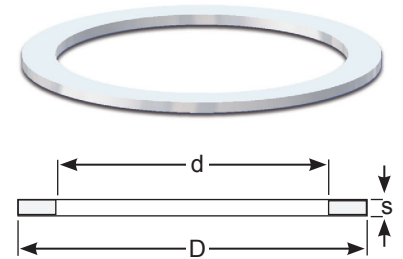

Notice! Seals are not included when you order flanges. You have to order Seals separately.

Flat Seals for thread - 2/2

Standard sizes of PUR (VULKOLLAN® polyurethane elastomer), injection molded. Colour:blue.Other sizes of PUR (VULKOLLAN® Cast polyurethane). Colour: honey-coloured. **Vulkollan®** is a registered trademark of Bayer

| Weight Appr. ≈ Kg | Suitable for | Dimensions ≈ mm | | | Product No |
|-------------------|----------------------------|-----------------|-----|-----|------------|
| | | D | d | s | |
| 0,001 | BSP 3/4" | 26 | 19 | 2 | 1498-09 |
| 0,001 | BSP 1" | 33 | 24 | 2 | 1220-09 |
| 0,001 | BSP 1 1/4" (DN 25 + DN 32) | 42 | 34 | 2 | 1536-09 |
| 0,002 | BSP 1 1/2" (DN 32 + DN 38) | 48 | 39 | 2 | 1196-09 |
| 0,003 | BSP 1 3/4" | 54 | 44 | 2,5 | On request |
| 0,003 | BSP 2" | 60 | 49 | 2 | 1052-09 |
| 0,005 | BSP 2 1/2" | 76 | 63 | 2,5 | 1181-09 |
| 0,006 | BSP 3" | 88 | 77 | 3 | 1110-09 |
| 0,010 | BSP 3 1/2" | 100 | 80 | 3 | On request |
| 0,009 | BSP 4" | 114 | 100 | 3 | 1295-09 |
| 0,012 | BSP 5" (No standard) | 140 | 124 | 3 | On request |
| 0,016 | BSP 6" | 164 | 150 | 3 | 1963-09 |

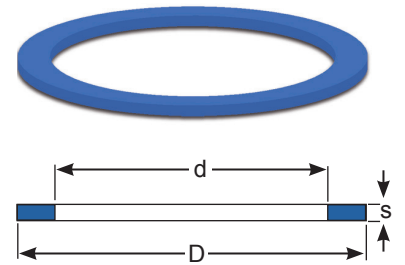

ELAPAC Flange Seals FD, QFD

| Flange Standard / Suitable for | Dimensions ≈ mm | | | | | Product No |
|--------------------------------|-----------------|------|-----|---------|---|------------|
| | D | d | Øk | Øh | s | |
| DN 25 PN 10/16 | 108 | 78,5 | 91 | 4 x 6,5 | 2 | - |
| DN 32 PN 10/16 | 140 | 43 | 100 | 4 x 18 | 2 | - |
| DN 50 PN 6 | 140 | 61 | 110 | 4 x 15 | 2 | - |
| DN 50 TW 1 | 154 | 50 | 130 | 8 x 12 | 2 | - |
| DN 80 TW 1 | 154 | 90 | 130 | 8 x 12 | 2 | - |
| DN 50 PN 10/16 | 165 | 61 | 125 | 4 x 18 | 2 | - |
| DN 100 TW3 | 174 | 110 | 150 | 8 x 14 | 2 | - |
| DN 65 PN 10/16 | 185 | 76 | 145 | 4 x 18 | 2 | - |
| DN 80 PN 10/16 | 200 | 90 | 160 | 8 x 18 | 2 | - |
| DN 125 TW5 | 204 | 135 | 176 | 8 x 14 | 2 | - |
| DN 100 PN 10/16 | 220 | 115 | 180 | 8 x 18 | 2 | - |
| DN 150 TW7 | 240 | 160 | 210 | 12 x 14 | 2 | - |
| DN 125 PN 10/16 | 250 | 141 | 210 | 8 x 18 | 2 | - |
| DN 150 PN 10/16 | 280 | 169 | 240 | 8 x 22 | 2 | - |
| DN 200 PN 10 | 340 | 220 | 295 | 8 x 22 | 2 | - |
| DN 200 PN 16 | 340 | 220 | 295 | 12 x 22 | 2 | - |

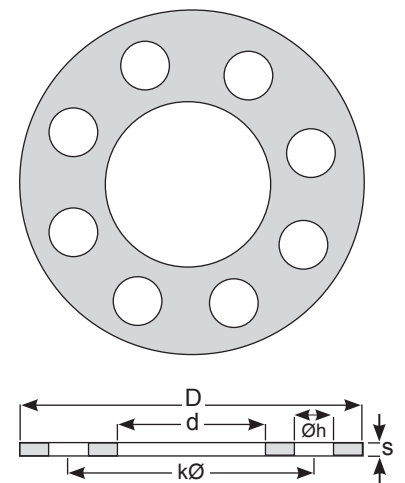

Notice! Seals are not included when you order flanges. You have to order Seals separately.

Explanation of Designations - 1/2

Ver 1301

First sign (letter): Indicates the type of coupling

A = API-adaptor
 AV = Tank Unit (EN 13081)
 B = Ball Valve
 C = Dust Cap
 CG = Dust Cap LPG
 D = Swivel
 E = Tank Unit with pressure valves
 F = Hose Unit (ISO 45)
 G = Tank Unit (ISO 45)
 GS = Tank Unit (ISO 45) with selectivity

H = Sampling Vent & Drain Unit
 I = Dust Plug ISO 45
 K = Dust Cap ISO 45
 L = Tank Unit LPG
 LC = Tank Unit Cryogenic
 M = Hose Unit LPG
 MC = Hose Unit Cryogenic
 N = Break Away Pin
 NC = Break Away Pin Cryogenic
 O = Break Away Wire

P = Dust Plug
 R = Pressure Cap
 RG = Pressure Cap LPG
 S = Hose Unit (STANAG 3756)
 SN = Hose Unit int. Break Away Pin
 SO = Hose Unit int. Break Away Wire
 T = Tank Unit (STANAG 3756)
 U = Filter / Sight Glass
 V = Dust Plug LPG
 WA = Hose Fittings

Second sign (numeral): Indicates the socket diameter and/or the nominal diameter

0 = 50mm or 3/4"
 1 = 56mm or 1", 1 1/4"
 2 = 70mm or 1 1/2", 2"
 3 = 105mm or 2 1/2"

4 = 119mm or 3"
 5 = 164mm or 4"
 V = 5"
 6 = 238mm or 6"

8 = 272mm or 8"
 10 = 10"
 12 = 12"

Third and fourth sign (numeral): Indicates connection, (thread, flange etc.)

01 = 3/4" BSP (Female)
 02 = 3/4" NPT (Female)
 03 = 1" BSP (Female)
 04 = 1" NPT (Female)
 05 = 1 1/4" BSP (Female)
 06 = 1 1/4" NPT (Female)
 07 = 1 1/2" BSP (Female)
 08 = 1 1/2" NPT (Female)
 09 = 1 3/4" BSP (Female)
 10 = 2" BSP (Female)
 11 = 2" NPT (Female)
 12 = 2 1/2" BSP (Female)
 13 = 2 1/2" NPT (Female)
 14 = 3" BSP (Female)
 15 = 3" NPT (Female)
 16 = 4" BSP (Female)
 17 = 4" NPT (Female)
 18 = Flange undrilled Ø156
 19 = Flange undrilled Ø165
 20 = Flange undrilled Ø210
 21 = Flange undrilled Ø230
 22 = Flange undrilled Ø254
 23 = Flange DN 25 PN 10/16
 24 = Flange DN 25 PN 25/40
 25 = Flange DN 32 PN 10/16
 26 = Flange DN 32 PN 25/40
 27 = Flange DN 40 PN 10/16
 28 = Flange DN 40 PN 25/40
 29 = Flange DN 50 PN 25/40*
 30 = Flange DN 50 PN 10/16
 31 = Flange DN 50 PN 25/40
 32 = Flange DN 65 PN 25/40*
 33 = Flange DN 65 PN 10/16
 34 = Flange DN 65 PN 25/40
 35 = Flange DN 80 PN 25/40*
 36 = Flange DN 80 PN 10/16
 37 = Flange DN 80 PN 25/40
 38 = Flange DN 100 PN 25/40*
 39 = Flange DN 100 PN 10/16
 40 = Flange DN 100 PN 25/40
 41 = Flange DN 125 PN 6
 42 = Flange DN 125 PN 10/16
 43 = Flange DN 125 PN 25/40
 44 = Flange DN 150 PN 6
 45 = Flange DN 150 PN 10/16
 46 = Flange DN 150 PN 25/40
 47 = Flange DN 20 PN 10/16
 48 = Flange DN 20 PN 25/40
 49 = Flange 3/4" ANSI Class 150
 50 = Flange 3/4" ANSI Class 300
 51 = Flange 1" ANSI Class 150
 52 = Flange 1" ANSI Class 300
 53 = Flange 1 1/4" ANSI Class 150
 54 = Flange 1 1/4" ANSI Class 300
 55 = Flange 1 1/2" ANSI Class 150
 56 = Flange 1 1/2" ANSI Class 300
 57 = Flange 2" ANSI Class 150
 58 = Flange 2" ANSI Class 300
 59 = Flange 2 1/2" ANSI Class 150
 60 = Flange 2 1/2" ANSI Class 300
 61 = Flange 3" ANSI Class 150
 62 = Flange 3" ANSI Class 300
 63 = Flange 4" ANSI Class 150
 64 = Flange 4" ANSI Class 300
 65 = Flange TW 1 (3" - DN 80)
 66 = Flange TW 3 (4" - DN 100)
 67 = Flange 3" T.T.M.A.
 68 = Flange 4" T.T.M.A.
 69 = 3/4" BSP (Male)
 70 = 3/4" NPT (Male)
 71 = 1" BSP (Male)
 72 = 1" NPT (Male)
 73 = 1 1/4" BSP (Male)

74 = 1 1/4" NPT (Male)
 75 = 1 1/2" BSP (Male)
 76 = 1 1/2" NPT (Male)
 77 = 1 3/4" BSP (Male)
 78 = 2" BSP (Male)
 79 = 2" NPT (Male)
 80 = 2 1/2" BSP (Male)
 81 = 2 1/2" NPT (Male)
 82 = 3" BSP (Male)
 83 = 3" NPT (Male)
 84 = 4" BSP (Male)
 85 = 4" NPT (Male)
 86 = Weld.flange 2" Ø60,5 inner
 87 = Flange TW 1 (2" DN50)
 88 = Weld.flange 2" Ø50-Ø70 (flat)
 89 = Weld.flange 2" Ø57 (int. chamfer)
 90 = Weld.flange 2" Ø60 (outer chamfer)
 91 = Weld.flange 3" Ø75-Ø90 (flat)
 92 = Weld.flange 3" Ø76 (int. chamfer)
 93 = Weld.flange 3" Ø89 (outer. chamfer)
 94 = Weld.flange 4" Ø100-Ø120 (flat)
 95 = Weld.flange 4" Ø102 (int. chamfer)
 96 = Weld.flange 4" Ø108 (int. chamfer)
 97 = Weld.flange 4" Ø114 (outer. chamfer)
 98 = Flange TW 1 (2" - DN 50) with drain connection
 99 = Flange DN 150 PN 25
 100 = Flange 6" ANSI Class 150
 101 = Flange 6" ANSI Class 300
 102 = Flange DN 200 PN 10
 103 = Flange DN 200 PN 16
 104 = Flange DN 200 PN 25
 105 = Flange 8" ANSI Class 150
 106 = Flange 8" ANSI Class 300
 107 = Flange Square ISO 45
 108 = S60x6 (Female)
 109 = S60x6 (Male)
 110 = 6" BSP (Female)
 111 = 6" NPT (Female)
 112 = W2" - 7 (Female)
 113 = Weld.flange 3" Ø92 inner
 114 = Square flange, 4 holes
 115 = 6" BSP (Male)
 116 = 6" NPT (Male)
 117 = 8" NPT (Female)
 118 = 4" Victaulic
 119 = Flange DN 50 PN 25/40**
 120 = Flange DN 65 PN 25/40**
 121 = Flange DN 80 PN 25/40**
 122 = Flange DN 100 PN 25/40**
 123 = W2" - 7 (Male)
 124 = 5" NPT (Female)
 125 = 5" NPT (Male)
 126 = Flange DN 100 PN6
 127 = Flange DN 80 PN6
 128 = Flange DN 65 PN6
 129 = Flange DN 50 PN6
 130 = Flange 8" ANSI Class 600
 131 = W90x1/6" (Female)
 132 = 1/2" NPT (Female)
 133 = 1/2" BSP (Female)
 134 = Flange Ø184,2, 6 holes
 135 = Flange TW 7 (6" - DN 150)
 136 = 4" ASSPT (Female)
 137 = Triclamp DN 25
 138 = M54x 1,5 (Female)
 139 = Triclamp DN 50
 140 = Weld.flange Ø73 (outer chamfer)
 141 = 3" Victaulic
 142 = Flange 5" ANSI Class 150
 143 = 3" Ball valve
 144 = 2" Victaulic
 145 = 3" BSPT (Male)

146 = 5" Victaulic
 147 = 2" BSPT (Female)
 148 = 2" BSPT (Male)
 149 = 1 1/2" Victaulic
 150 = 2 1/2" Victaulic
 151 = Flange 1" DIN 11864-2
 152 = Flange 2" DIN 11864-2
 153 = Flange Ø135, 8xM6
 154 = 4" BSPT (Female)
 155 = 4" BSPT (Male)
 156 = Weld flange 2" ø61,5 (inner)
 157 = 3" BSPT (Female)
 158 = Weld end 1 1/2" ø48 (outer)
 159 = Thread TR 57x4
 160 = Flange 2" BS10 Table D
 161 = Flange 12" ANSI Class 150
 162 = Flange 10" ANSI Class 150
 163 = Flange DN 250 PN 16
 164 = M130x6 (Female)
 165 = Flange 10" ANSI Class 300
 166 = ACME 1 1/4" (Female)
 167 = ACME 1 1/4" (Male)
 168 = ACME 2 1/4" (Female)
 169 = ACME 3 1/4" (Female)
 170 = ACME 1 1/4" (Male)
 171 = ACME 1 3/4" (Male)
 172 = ACME 2 1/4" (Male)
 173 = ACME 3 1/4" (Male)
 174 = Weld.flange Ø76 (outer. chamfer)
 175 = Flange DN 15 PN 10/16
 176 = Flange DN 15 PN 25/40
 177 = M130x6 (Male)
 178 = Flange 6" T.T.M.A.
 179 = Flange DN 80 PN 25/40***
 180 = 1/2" NPT (Male)
 181 = 1/2" BSP (Male)
 182 = 5" BSP (Female)
 183 = 5" BSP (Male)
 184 = Weld end 8" ø219 (outer)
 185 = Weld end 6" ø168 (outer)
 186 = Flange DN 250 PN 25
 187 = Flange 2" T.T.M.A.
 188 = Flange 3" BS10 Table D
 189 = Flange 1/2" ANSI Class 150
 190 = Flange 1" ANSI Class 150 Flat Face
 191 = Flange 12" ANSI Class 300
 192 = Flange DN250 PN10
 193 = Weld end Ø114 Schedule 40
 194 = Weld end Ø114 Schedule 80
 195 = 6" Victaulic
 196 = 1" Victaulic
 197 = DN 125 JIS 5K
 198 = DN 100 JIS 5K
 199 = DN 80 JIS 5K
 200 = DN 50 JIS 5K
 201 = DN 40 JIS 5K
 202 = Flange 2" DIN 11864-3
 203 = 3 1/2" BSP (Female)
 204 = Flange Ø110, Ø86/Ø5,5 (6x)
 205 = Weld end Ø60 Schedule 80
 206 = Weld end Ø89 Schedule 40
 207 = Weld end Ø89 Schedule 80
 208 = Flange DN 25 PN 6
 209 = Flange DN 32 PN 6
 210 = Flange DN 40 PN 6
 211 = DN 125 JIS 10K
 212 = DN 100 JIS 10K
 213 = DN 80 JIS 10K
 214 = DN 50 JIS 10K
 215 = DN 40 JIS 10K
 216 = Flange DN 80, holes Ø14 (6x)
 217 = Flange 5" ANSI Class 300

* EN 1092-1:2001 Type E: Spigot

** EN 1092-1:2001 Type F

*** EN 1092-1:2001 Type C

No part of this leaflet may be reproduced in any form or by any means without permission in writing from the publisher.

NOTE! When swivels are chosen, the second and the third sign indicates one outlet, the fourth and the fifth sign the second outlet.

No part of this leaflet may be reproduced in any form or by any means without permission in writing from the publisher.

Fifth sign (letter): Indicates version

| | | |
|--------------------------------------|----------------------------------|------------------------------|
| A = Version No.1 (Machined from bar) | G = Drain connection | P = Pressure (Custom) |
| B = Version No.2 (Casted) | H = Leaf spring lock | S = Sight Glass |
| C = Version No.3 (Kokill casted) | I = Bended Tank Unit Short (15°) | T = Transparent |
| D = Sep. piston guide | J = Bended Tank Unit (15°) | U = Stop before disconnected |
| E = Injection moulded | K = Short Tank Unit/Swivel | |
| F = 6" Flange Hydrant | N = Non Return Valve | |

Sixth sign (numeral): Indicates material in the coupling body

| | |
|------------------------------|---------------|
| 1 = Aluminium | 6 = Titan |
| 2 = Brass | 7 = Hastelloy |
| 3 = Steel | 8 = PVDF |
| 4 = Stainless steel A4 (316) | 9 = PEEK |
| 5 = Stainless steel A2 (304) | K = Inconel |

Seventh sign (numeral): Indicates material in the innerparts or other components

| | |
|------------------------------|---------------|
| 1 = Aluminium | 6 = Titan |
| 2 = Brass | 7 = Hastelloy |
| 3 = Steel | 8 = PVDF |
| 4 = Stainless steel A4 (316) | 9 = PEEK |
| 5 = Stainless steel A2 (304) | K = Inconel |

Eight and Ninth sign (numeral): Indicates the O-ring material in the coupling

| | | |
|------------------------------------|--|---|
| 01 = Viton® (FPM/FKM) | 16 = Hypalon® (CSM) | 37 = Chemraz® 510 (90 Shore) |
| 02 = Nitrile (NBR) | 17 = Chemraz® 505 (FFKM) | 40 = FEP PTFE encapsulated Viton® |
| 03 = EPDM | 18 = Xyflour® 860 (AFKM) | 50 = Kalrez® (PFPM) 1050LF |
| 04 = Kalrez® (FFKM) 6375 | 19 = Zetpol® / Therban® (HNBR) | 51 = Nylon® (PA) |
| 05 = NBR Low temp | 20 = NBR 90 shore | 61 = Viton® (FPM), FDA, USP C6 & ADI |
| 06 = Teflon® (PTFE) | 21 = Viton®-GF (Special Viton quality) | 62 = Nitrile (NBR), FDA, USP C6 & ADI |
| 07 = Neoprene® (CR) | 22 = Composite | 63 = EPDM, FDA, USP C6 & ADI |
| 08 = Silicone (Q) | 23 = Viton® GFLT-S | 64 = Kalrez® (FFKM) 6230, FDA, USP C6 & ADI |
| 09 = Vulkollan® (PUR) | 24 = Viton® GLT | 66 = PTFE (Virgin), FDA |
| 10 = Butyl (IIR) | 25 = Klingerit® | 71 = FPM/FKM Low Temp |
| 11 = Nitrile (Gasol NBR 70 K-6) | 26 = POM | 77 = Chemraz® SD517, FDA, USP C6 & ADI |
| 12 = Perfluorelastomer (FFPM/FFKM) | 27 = Epiclorydrin (ECO) | 83 = EPDM BAM |
| 13 = PVC / NBR | 28 = Viton® GFLT-S NMO | |
| 14 = Fluorsilicone rubber (MFQ) | 31 = Viton® 90 Shore (FPM/FKM) | |
| 15 = FEP encapsulated silicone | 33 = EPDM 291 | |
| | 34 = Kalrez® 0040 | |

Tenth sign (letter): Used for extra

| | | |
|---------------------------------------|--------------------------------------|-------------------------------------|
| A = Flat seal, Teflon®(PTFE) | M = Modified Cam Curve | V = Locking house unit |
| B = Flat seal, Vulkollan®(PUR) | N = No Branding | W = Double ball race |
| C = 2-way Ball Valve | NA = No Actuator (Ball Valve) | X = Special surface treatment |
| D = Flat seal, Viton® (FPM) | P = Pressure Equalizing Valve | Z = Excentric tank unit |
| DA = Double Acting (Ball Valve) | Q = Reduced bore diameter | -RA = Racing |
| E = None projecting piston spindle | (Argus,Hydrant) | -LC = Locking Cap |
| F = Flange thickness acc. to standard | R = Hose unit with int. Break Away | -S = FEP O-ring in Hose Unit swivel |
| G = Hypalon | S = Single Argus valve (Hydrant) | -ST = Steam |
| H = Nitrile (NBR) | SR = Spring Return (Ball Valve) | -XL = Oversized swivel |
| I = Emco comp | T = TW-Flange extended circles | -45 = 45 Mesh |
| J = EPDM | U = Pressure Bleeding Valve 16 bar | -60 = 60 Mesh |
| K = Locked piston guide | U5 = Pressure Bleeding valve 5 bar | -10 = 100 Mesh |
| L = Locked thread | U20 = Pressure Bleeding valve 20 bar | |

No part of this leaflet may be reproduced in any form or by any means without permission in writing from the publisher.

No part of this leaflet may be reproduced in any form or by any means without permission in writing from the publisher.

Design may change without notice

No part of this leaflet may be reproduced in any form or by any means without permission in writing from the publisher.

| | |
|------------|-----------|
| Date | Name |
| Title | Company |
| Department | Address |
| Country | Telephone |
| E-mail | Fax |

Product data

| | |
|---|-------------|
| Code No. | Quantity |
| | |
| Internal diameter: | Connection: |
| Product type/spec/options: | |
| Size <input type="text"/> Integrated Breakaway <input type="checkbox"/> Pressure release valve <input type="checkbox"/> | |
| Other options : | |
| Material | |
| Other remarks | |
| Pressure certificate <input type="checkbox"/> Material Certificate 3.1 <input type="checkbox"/> | |

Flow data (Media Cast No)

Cleaning process

| | | | |
|------------------|-------------|---------------|--------|
| 1 | ⋮ | | |
| 2 | ⋮ | | |
| 3 | ⋮ | | |
| 4 | ⋮ | | |
| 5 | ⋮ | | |
| Working Pressure | Temperature | Concentration | Vacuum |

Customers note

Mann Teknik AB
 Mariagatan 29
 542 43 Mariestad
 Sweden

46-(0)501 39 32 00

46-(0)501 39 32 09

www.mann-tek.com
 sales@mann-tek.se

About

Mann Tek is a Swedish manufacturer and supplier of Safety breakaway couplings with experience of the industry for more than 20 years. We supply modern, easy to use, safe and timesaving products. A environmentally safe system for both staff and its surroundings, which prevents a variety of hazards. Our products are the obvious choice in harsh and demanding environments and where there's a need of a safe and spill free handling of fluids, gases and bulk powders. With more than twenty years of knowledge and experience of multiply industries it has accumulated extensive expertise about applications in many types of variations in which our couplings have been, and can be used, with excellent results.



We constantly strive to develop and improve the performance and design of our products, to meet changes, new market demands and standards. Which, today, is what made us market leading.

Our couplings are the obvious choice when certifications and product approvals are required, anywhere in the world.

Mann Tek® is certified to ISO9001:2008 and the products are produced in accordance with several important standards, e.g. the NATO STANAG 3756, NATO STANAG 3105, ISO 45, MS24484, British Aerospace Specification 2C14

Company Approvals



Mann-Tek is a certified ISO9001-company.

Phone: +46 501 39 32 00
Fax: +46 501 39 32 09
Email: sales@mann-tek.com
Web site: www.mann-tek.com
Address: Mann Teknik AB
Strandvägen 16
S-542 31 Mariestad
Sweden

Sales office:
Argentina | Great Britain | Netherlands
Sweden | United Arab Emirates