

CVS120 - Check Valve Spool, 100MM (4")

The CVS120 series check valve spool is designed to hold back the product in the loading arm so that the pipework will not drain when the API coupler is opened.

Since the arm can no longer be drained by just opening the coupler, 2 drain bosses have been incorporated into the valve. One on the API side of the poppet, to allow product to be drained from the outlet side of the CVS120, for removal and servicing of the API coupler. The second is on the loading arm side of the poppet to allow sampling or complete draining of the loading arm for servicing and repair of up stream components like the outboard swivel and hose.



CVS120 3D Model Shown

Features and Benefits

- **Holds product back in the loading arm** - Pipework will not drain when the API coupler is opened.
- **Can be used to avoid product contamination** - For example if the arm is accidentally connected to the wrong compartment and the coupler opened, only a small volume of product can spill into the tanker prior to pumping starting. If this mistake is identified and corrected prior to loading, product contamination can be avoided.
- **Prevents Pilfering** - By drainage of the drop hose section pilfering can be prevented.
- **Allows visual identification of product** - kits with sightglasses and fasteners available to allow visual identification of product.
- Product flow through the loading arm opens the poppet inside the check valve spool.

Technical Information

Mounting	100mm (4") TTMA Flanges.
Materials	Aluminium body, poppet and spider Stainless Steel spring & high tensile steel shaft Viton product seal. Brass drain plugs and over pressure valve.
Opening Pressure (in flow direction)	45kPa (6.5 PSI)
Over pressure (in non-flow direction)	30kPa (4.5 PSI) (emergency relief in reverse direction to allow for thermal expansion).
Weight	4.5kg (9.9lb)
Dismantle	Remove from loading arm. Clamp valve between the two flanges. Remove the 2 countersunk screws. Carefully loosen the clamps and allow the spring to reach its free length. Remove spring & poppet assembly by tilting the poppet.

Ordering Information

- **CVS120:** 4" check valve spool.
- **CVS120Z:** 4" Check Valve Spool kit for load arms c/w gasket and mounting fasteners.
- **CVS120SGZ:** 4" Check Valve Spool kit for load arms c/w gasket, mounting fasteners and flanged sightglass.

Associated Equipment

- **VSA4:** 15 degree spool.
- **VSS4:** straight spool.
- **BF4-SG-25:** 4" TTMA Acrylic sightglass, 25mm thick.
- **BF4-SG-40:** 4" TTMA Acrylic sightglass, 40mm thick.

CVS120 HOLD BACK VALVE

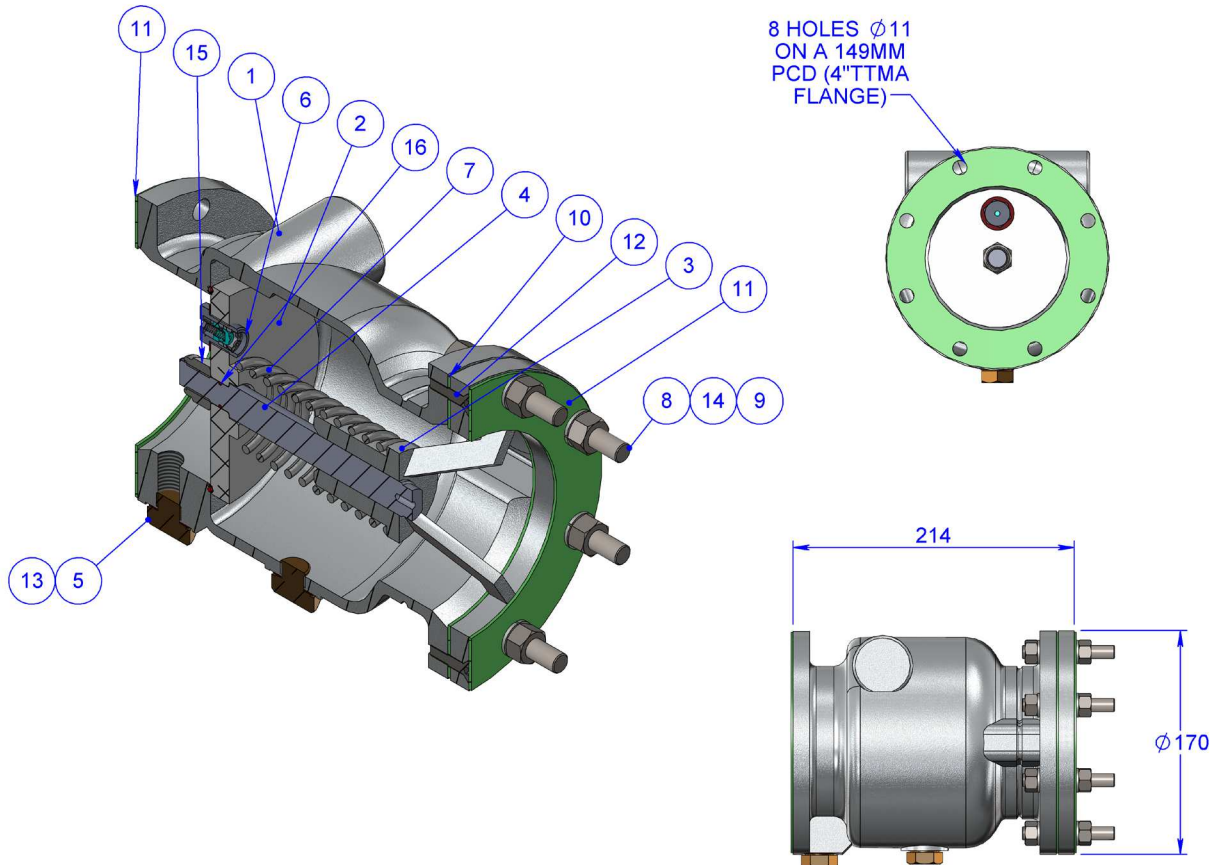

ITEM	PART NUMBER	DESCRIPTION	QTY.	MATERIAL
1	CVS110-1	MAIN BODY	1	ALUMINIUM
2	CVS120-3	POPPET HOLD BACK VALVE	1	ALUMINIUM
3	CVS120-4	SPIDER	1	ALUMINIUM
4	CVS120-5	SHAFT	1	STEEL
5	PCU201-7	PLUG M16	2	BRASS
6	CVM103	CHECK VALVE MINIATURE	1	ASSEMBLY
7	6167	SPRING	1	SPRING STEEL
8	6665	STUD	8	ST STEEL
9	5261	WASHER SPRING	16	Z/P STEEL
10	7557	GASKET TTMA 100mm (4")	1	KLINGER SIL
11	4248	GASKET TTMA 100mm (4")	2	KLINGER SIL
12	6657	CAPSCREW C/SUNK METRIC	2	Z/P STEEL
13	0885	WASHER FIBRE	3	FIBRE
14	6473	NUT METRIC	16	ST STEEL
15	55098	CONELock NUT	1	Z/P STEEL
16	7622	O-RING	1	VITON A

LIQUIP

See website for Liquip branches and distributors - www.liquip.com

X300015

Issue: A