

A-SERIES VALVES

Installation, Maintenance & Operating Instructions

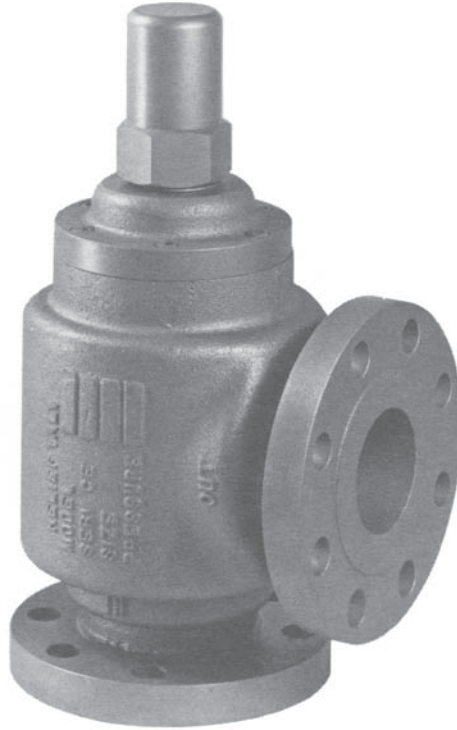

APPLICATION

The Fulflo A-Series feature both direct acting and internal pilot operated models with either screw or flange type connections. The threaded valves are available in both 2½" and 3" sizes in either cast iron or steel. The flange type valves also include a 4" model and may be specified with 150#, 300# or 600# ANSI flanges. Note that 600# is available in Steel and SS only.

The direct acting valves operate at pressures to 150 P.S.I.; the internal pilot operated models at

pressures to 500 P.S.I. Both types handle large flows of liquid of all viscosities encountered in industrial practice.

The A-Series valves may be used in a variety of applications including hydraulic and lubrication systems for load regulation and system protection.

Unusual applications and special valves should be referred to our engineering staff for recommendation.

INSTALLATION

Fulflo valves can be mounted in any position. A tee may be inserted in the pump discharge line to mount the valve. The pipe lines carrying the heavy valves must be well supported and overhung weights avoided. The correct size of valve must be used, preferably equal to the size of the pipe line to which they are connected. Threaded valves (AAD and ACD) may be

threaded into pipe nipples. Overhung weights on threads should be avoided. Flanged valves (AADF and ACDF) are bolted to the companion flange which may be threaded or welded to the pipe. The outlet of the valve should be piped to the supply tank, unless specific applications call for alternate piping of return lines. Care must be taken to have the discharge well below the oil level in the tank to prevent air entrainment and erratic operation.

SETTING VALVES

Valve may be set with a hydraulic hand pump for cracking pressure. If a test stand is available, valve should be connected to the discharge header with the pump bypass open, and the bypass gradually closed until the desired pressure registers on the gauge. **“Direct”** Adjust valve adjusting screw until valve slightly bleeds at the set bypass pressure and lock adjusting screw. **“Pilot”** Adjust valve adjusting screw until approximately 5-7 GPM is flowing through the valve, at that point the main piston will open and then the valve will be considered at the set point, then lock adjusting screw. If a valve is required to bypass a given amount of fluid at a given

pressure, a test stand having a flow meter in the pump discharge line must be available. With a valve adjusting for cracking pressure as above, continue closing bypass until the required flow registers on the flow meter and observe pressure. Readjust pressure, if necessary, to obtain desired pressure at desired flow.

MAINTENANCE

Fulflo valves provide reliable “chatter-free” operation when the system is free of abrasives and foreign matter. Continuous filtration of the liquid used is strongly recommended.

DISASSEMBLY OF DIRECT ACTING VALVES

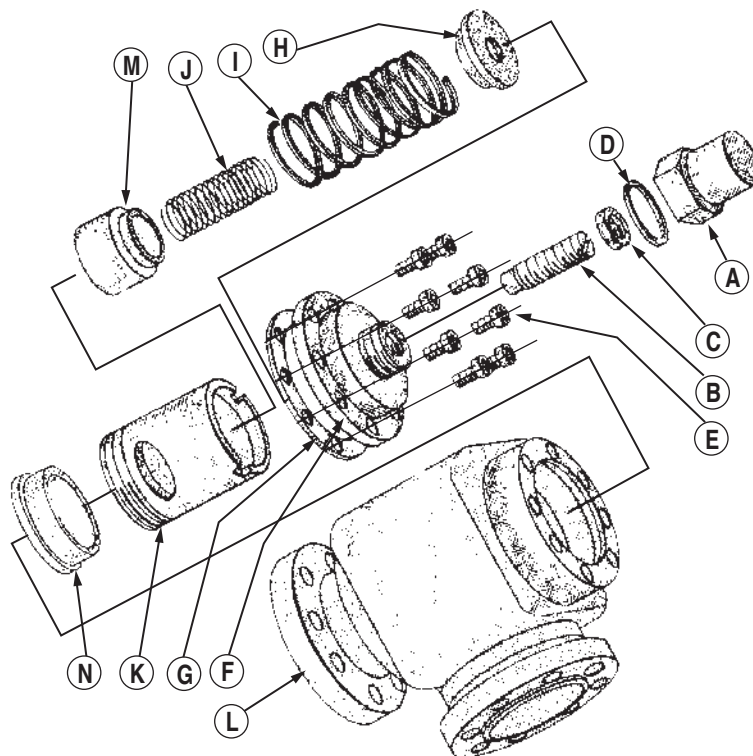

To dismantle the valve for inspection or cleaning:

1. Remove cap “A” and O-ring “D”
2. Remove lock nut “C”
3. Remove adjusting screw “B”
4. Remove cap screws “E”
5. Remove bonnet “F”
6. Remove gasket “G”
7. Remove spring retainer “H”
8. Remove spring or springs “I” and “J”
9. Remove piston “M”
10. Unscrew and withdraw cylinder “K”

11. Remove retaining bushing “N” if necessary

Inspect cylinder bore and piston for wear or scoring. Replace broken or damaged parts. Clean all parts thoroughly and re-assemble as follows:

Reverse process of disassembly from operation 11 to 6, then thread adjusting screw “B” into bonnet “F” so that it may be guided into the recess of spring retainer “H”, while re-assembling bonnet “F” to body “L”. Then proceed with steps 5, 4, 2, 1, in reverse order.

A-SERIES ASSEMBLY NUMBER IDENTIFICATION CHART

Symbol No.	Designation	Code	Description
1	Series	A	
2	Material	A C SS	Cast Iron Cast Steel Stainless Steel
3	Type	D P	Direct Acting Internal Pilot Operated
4 & 5	Size	09 10 11	2 1/2" 3" 4"
6	Connection	None F	Screw Type (2 1/2" and 3" only) Flange
7,8,9	ASA Flange Rating	150# 300# 600#	
10	Flange Style Only	A B C D	Raised Face, Staggered Bolt Centers Smooth Face, Staggered Bolt Centers Raised Face, Bolts on Valve Centerline Smooth Face, Bolts on Valve Centerline
11	O-Ring Material	R RV RS RT RA EPR RN	Buna O-Ring Cap Seal (Standard) Viton O-Ring Cap Seal Silicone O-Ring Cap Seal Teflon O-Ring Cap Seal Atlas O-Ring Cap Seal Ethylene Propylene Neoprene
12	Piston Material	/HS /SS /3SS	Hardened Steel 416 Stainless Steel 303 Stainless Steel (For Stainless Valves Only)
13	Spring	SPRING PART NUMBER	See Below
14	Setting		Desired Set Pressure

EXAMPLE:

ACP09R				
A	C	P	09	R
Series	Steel	Pilot Operated	2 1/2"	Buna

NOTE: Special valves are prefixed by numbers assigned by the factory.

EXAMPLE:

Specify:

1. Valve Model Number (1-10)
2. O-Ring Identification Number (11)
3. Piston Material (12)
4. Spring Part Number (13)
5. Spring pressure range or desired pressure setting. (14)

SERIES "A" VALVES (Direct Acting) PRESSURE RANGE CHART

Valve Size	Symbol	Spring Part No.	Pressure Range
2 1/2"	I	A0960D	7-57 P.S.I.
	I	A0961C	8-75 P.S.I.
	I & J	A0960D and A0970D	14-115 P.S.I.
	I & J	A0961C and A0971C	16-150 P.S.I.
3"	I	A1060D	5-50 P.S.I.
	I	A1061C	5-67 P.S.I.

NOTE: Springs suffixed with "C" are Chrome Vanadium, "D" indicates Stainless Steel. For pressures other than listed, consult factory.

(Continued)

3"	I & J	A1060D and A1070D	10-100 P.S.I.
	I & J	A1061C A1071C	10-135 P.S.I.
4"	I	A1160D	2-37 P.S.I.
	I & J	A1160D and A1170D	4-75 P.S.I.

SERIES "A" VALVES (Pilot Operated)

Valve Size	Symbol	Spring Part No.	Pressure Range
2 1/2"	O & J	A0980D and A1190D	50-500 P.S.I.
3"	O & J	A1080D and A1190D	50-500 P.S.I.
4"	O & J	A1181D and A1190D	50-500 P.S.I.

A-SERIES 2½" and 3"

(Direct Acting)

DIMENSIONS

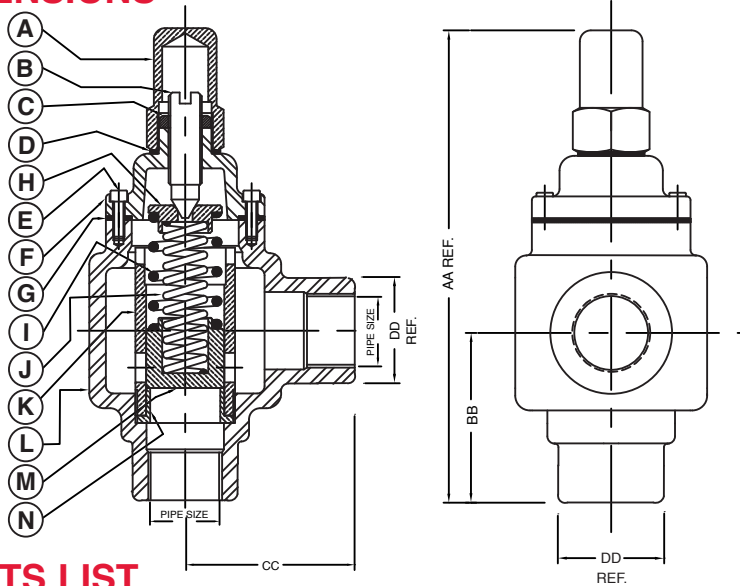

Valve Size	DIMENSIONS IN INCHES			
	AA	BB	CC	DD
2½"	15 ⁹ / ₁₆	5½	5 ¹ / ₁₆	4
3"	17½	6 ⁵ / ₈	6 ³ / ₈	4

PARTS LIST

SYMBOL	NAME	MODEL	VALVE SIZE	
			2½"	3"
A	Cap	AA, AC ASS	A1101CR A1101SSR	A1013CR A1013SSR
B	Adjusting Screw	AA, AC ASS	A0922C A0922SS	A1022C A1022SS
C	Lock Nut	AA, AC ASS	605-S 605-SS	705-S 705-SS
D	O-Ring †	AA, AC ASS	604- 604-*	704- 704-*
E	Cap Screw	AA, AC ASS	3/8 x 1 SHCS	3/8 x 1 SHCS
F	Bonnet	AA AC ASS	A0909A A0909C A0909SS	A1009A A1009C A1009SS
G	Gasket †	AA, AC ASS	A0903E A0903RT	A1003E A1003RT
H	Spring Retainer	AA, AC ASS	A0916C A0916SS	A1016C A1016SS
I	Spring †	AA, AC, ASS	See Chart	See Chart
J	Spring †	AA, AC, ASS	See Chart	See Chart
K	Cylinder †	AA, AC ASS	A0908C A0908SS	A1008C A1008SS
L	Body	AA AC ASS	A0900A A0900C A0900SS	A1000A A1000C A1000SS
M	Piston † Hardened Steel 416 Stainless Steel 303 Stainless Steel	AA, AC, AA, AC ASS (only)	A0906C A0906D A0906SS	A1006C A1006D A1006SS
N	Retaining Bushing	AA, AC ASS	A0911C A0911SS	A1011C A1011SS

*See o-ring selection chart † Recommended spare parts

A-SERIES VALVES

A-SERIES 2½", 3" and 4" (Direct Acting)

DIMENSIONS

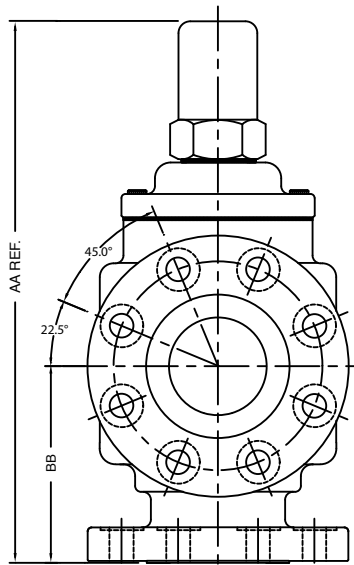
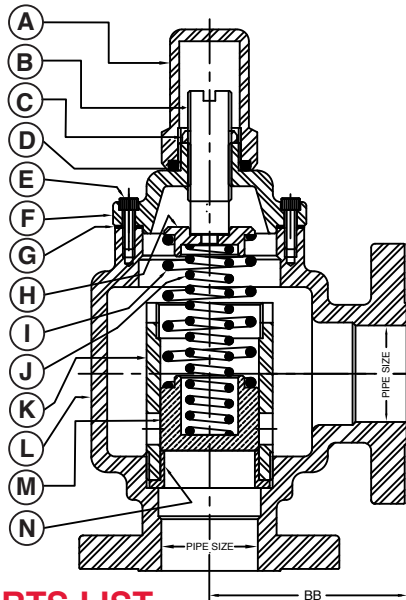

DIMENSIONS IN INCHES

Valve Size	Flange Rating	AA	BB
2½	150# 300#	15 ¹³ / ₁₆	5¾
2½	600#	16 ³ / ₁₆	6 ¹ / ₈
3	150# 300#	17 ¹ / ₈	6¼
3	600#	17½	6 ⁵ / ₈
4	150# 300#	20	7 ¹⁵ / ₁₆
4	600#	20 ³ / ₁₆	8 ¹ / ₈

Note! Refer to Page 10 for Flange and Drilling Dimensions.

PARTS LIST

SYMBOL	NAME	MODEL	VALVE SIZE		
			2½"	3"	4"
A	Cap	AA, AC, ASS	A1101CR A1101SSR	A1013CR A1013SSR	A1113CR A1113SSR
B	Adjusting Screw	AA, AC, ASS	A0922C A0922SS	A1022C A1022SS	A1122C A1122SS
C	Lock Nut	AA, AC, ASS	605-S 605-SS	705-S 705-SS	805-S 805-SS
D	O-Ring †	AA, AC, ASS	604- 604-*	704- 704-*	804- 804-*
E	Cap Screw	AA, AC, ASS	3/8 x 1 SHCS	3/8 x 1 SHCS	3/8 x 1 SHCS
F	Bonnet	AA AC ASS	A0909A A0909C A0909SS	A1009A A1009C A1009SS	A1109A A1109C A1109SS
G	Gasket †	AA, AC, ASS	A0903E A0903RT	A1003E A1003RT	A1103E A1103RT
H	Spring Retainer	AA, AC, ASS	A0916C A0916SS	A1016C A1016SS	A1116C A1116SS
I	Spring †	AA, AC, ASS	See Chart	See Chart	See Chart
J	Spring †	AA, AC, ASS	See Chart	See Chart	See Chart
K	Cylinder †	AA, AC, ASS	A0908C A0908SS	A1008C A1008SS	A1108C A1108SS
L	Body	AA AC ASS	A0900AF A0900CF A0900SSF	A1000AF A1000CF A1000SSF	A1100AF A1100CF A1100SSF
M	Piston † Hardened Steel 416-Stainless Steel 303-Stainless Steel	AA AC ASS (Only)	A0906C A0906D A0906SS	A1006C A1006D A1006SS	A1106C A1106D A1106SS
N	Retaining Bushing	AA, AC, ASS	A0911C A0911SS	A1011C A1011SS	A1111C A1111SS

*See o-ring selection chart

† Recommended spare parts

A-SERIES PERFORMANCE CHARTS

(Direct Acting)

All valve tests 110°F. to 120°F. Oil Viscosity 150 S.S.U. at 100°F.
(Charts good from 30 to 500 S.S.U.)

2 1/2" VALVE TESTS

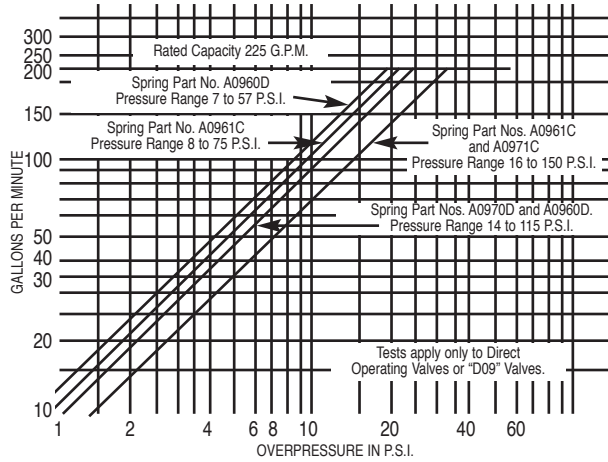

3" VALVE TESTS

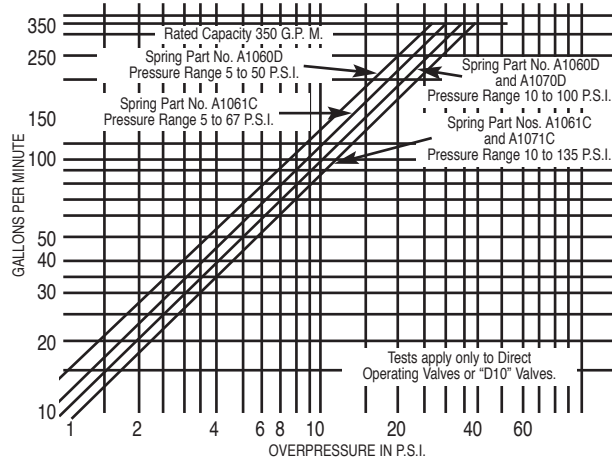

4" VALVE TESTS

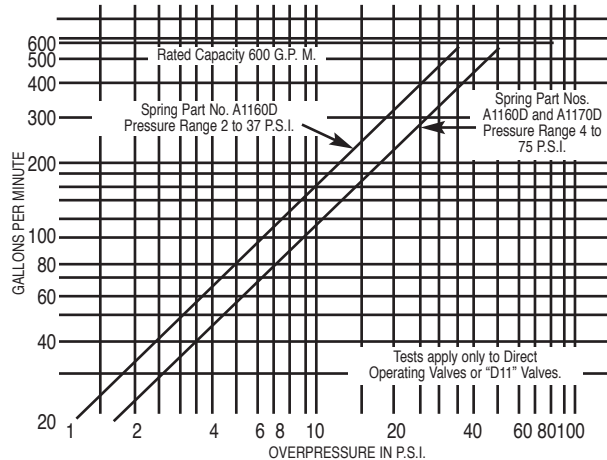

Overpressure - The pressure increase or accumulation above the set pressure when the valve is discharging flow.

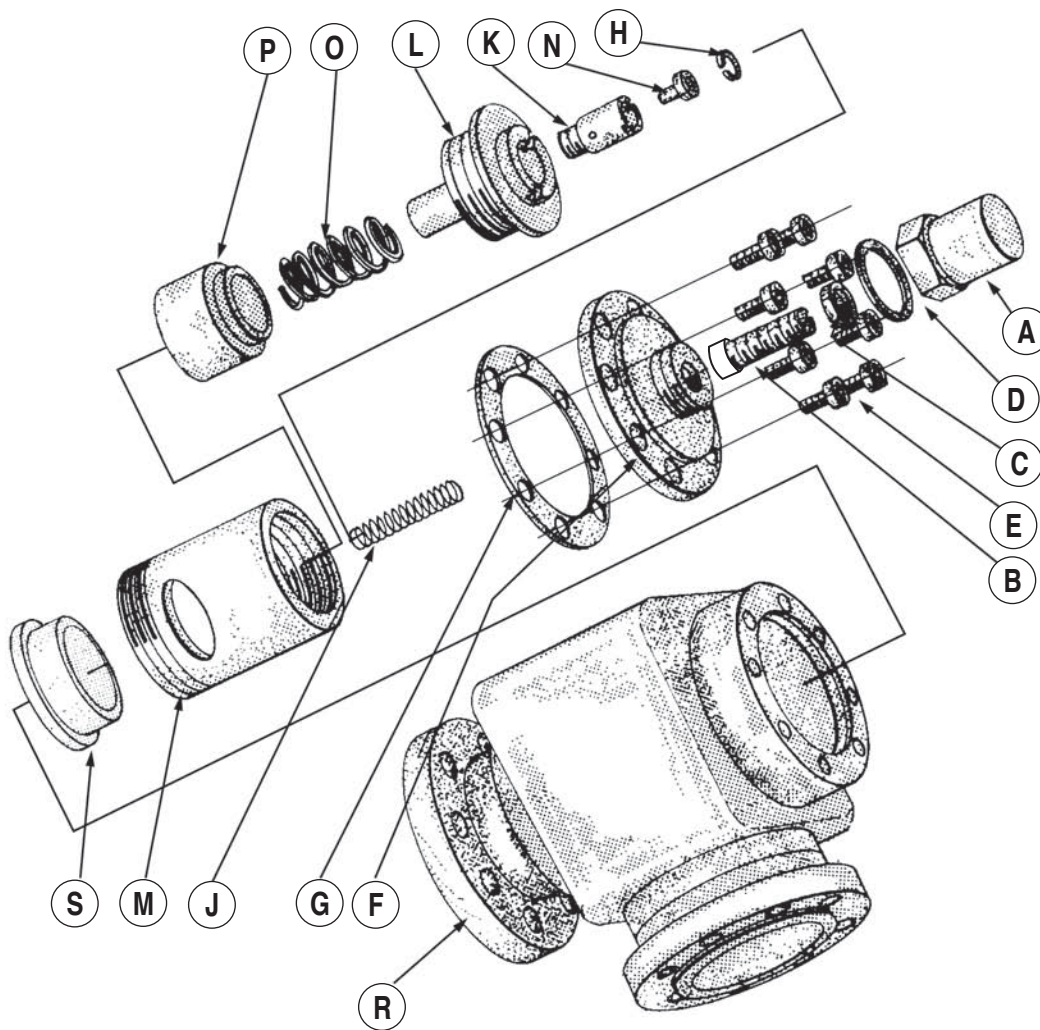

DISASSEMBLY OF INTERNAL PILOT OPERATED VALVES

To dismantle the valve for inspection or cleaning:

1. Remove cap "A" and gasket "D"
2. Remove nut "C"
3. Remove adjusting screw "B"
4. Remove cap screws "E"
5. Remove bonnet "F"
6. Remove gasket "G"
7. Remove pilot spring "J"
8. Unscrew and withdraw cylinder "M" (do not unscrew cylinder retainer "L")
9. Unscrew and remove cylinder retainer "L", after removing cylinder "M".
10. Unscrew and remove piston retainer "K"
11. Remove retaining ring "H"
12. Remove pilot piston "N"
13. Remove balance spring "O"
14. Remove piston "P"
15. Remove retaining bushing "S" if necessary

Inspect bores of both piston retainer "K" and cylinder "M". Inspect pistons "N" and "P" for wear or scoring. Replace broken or damaged parts. Clean all parts thoroughly and re-assemble as follows:

Reverse process of disassembly from operation 16 to 6, then thread adjusting screw "B" into bonnet "F", while re-assembling "F" to body "R". Then proceed with steps 5, 4, 2, 1 in reverse order.

Caution: hold in vise. Balance spring "O" under heavy compression.

10. Unscrew and remove piston retainer "K"
11. Remove retaining ring "H"

A-SERIES 2½" and 3" (Internal Pilot Operated)

DIMENSIONS

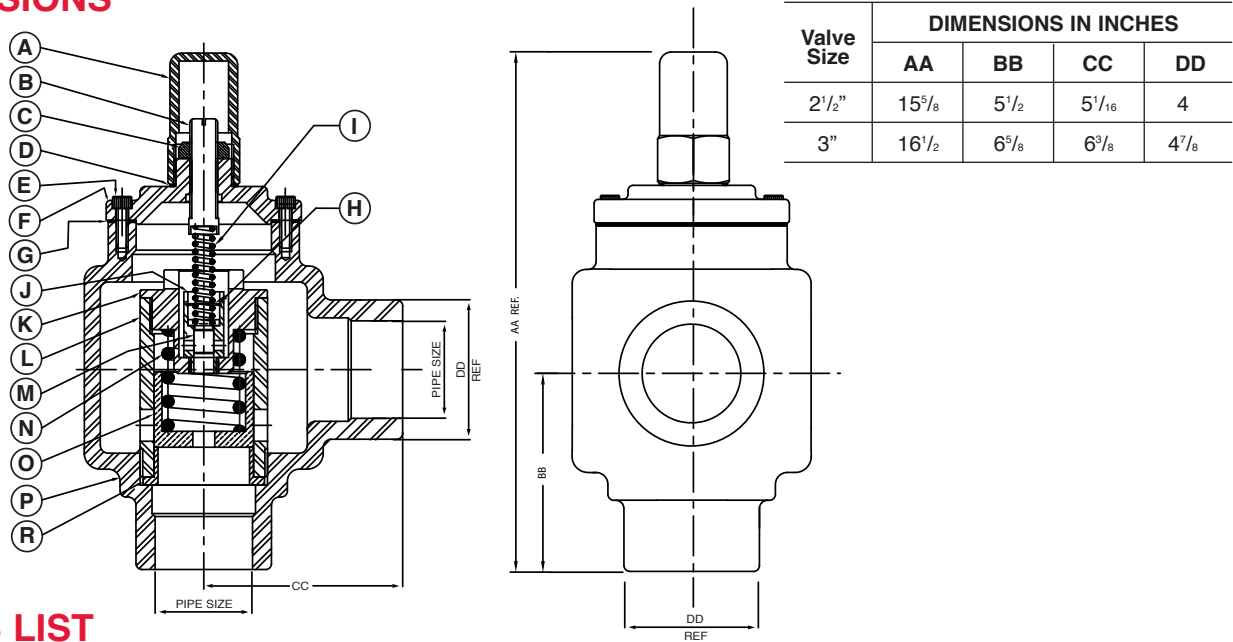

PARTS LIST

Symbol	NAME	VALVE SIZE		
		MODEL	2½"	3"
A	Cap	AA, AC ASS	A1101CR A1101SSR	A1101CR A1101SSR
B	Adjusting Screw	AA, AC ASS	A1102C A1102SS	A1102C A1102SS
C	Lock Nut	AA, AC ASS	505-S 505-SS	505-S 505-SS
D	O-Ring †	AA, AC, ASS	604-*	604-*
E	Cap Screw	AA, AC, ASS	3/8 x 1 SHCS	3/8 x 1 SHCS
F	Bonnet Cast Iron Steel Stainless Steel	AA AC ASS	A0919A A0919C A0919SS	A1019A A1019C A1019SS
G	Gasket †	AA, AC ASS	A0903E A0903RT	A1003E A1003RT
H	Retainer Ring †	AA, AC ASS	A1120D A1120SS	A1120D A1120SS
I	Pilot Spring †	AA, AC, ASS	A1190D	A1190D
J	Piston Retainer †	AA, AC ASS	A1118C A1118SS	A1118C A1118SS
K	Cylinder Retainer	AA, AC ASS	A0912C A0912SS	A1012C A1012SS
L	Cylinder †	AA, AC ASS	A0928C A0928SS	A1028C A1028SS
M	Pilot Piston † Hardened Steel 416 Stainless-Steel 303 Stainless-Steel	AA, AC AA, AC ASS (Only)	A1115C A1115D A1115SS	A1115C A1115D A1115SS
N	Balance Spring †	AA, AC, ASS	A0980D	A1080D
O	Piston † Hardened Steel 416 Stainless-Steel 303 Stainless-Steel	AA, AC AA, AC ASS (Only)	A0936C A0936D A0936SS	A1036C A1036D A1036SS
P	Body	AA AC ASS	A0900A A0900C A0900SS	A1000A A1000C A1000SS
R	Retaining Bushing	AA, AC ASS	A0911C A0911SS	A1011C A1011SS

* See o-ring selection chart † Recommended spare parts

A-SERIES VALVES

A-SERIES 2½", 3" and 4" (Internal Pilot Operated)

DIMENSIONS

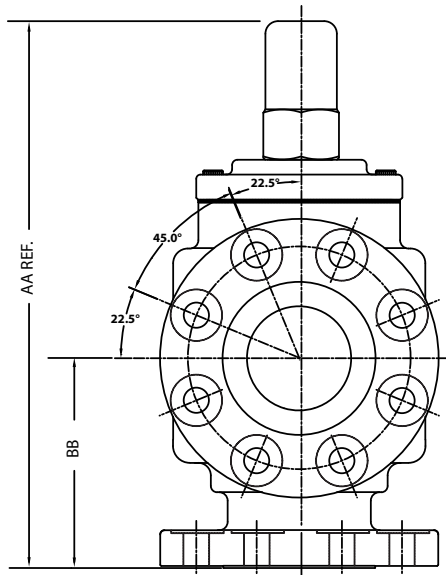
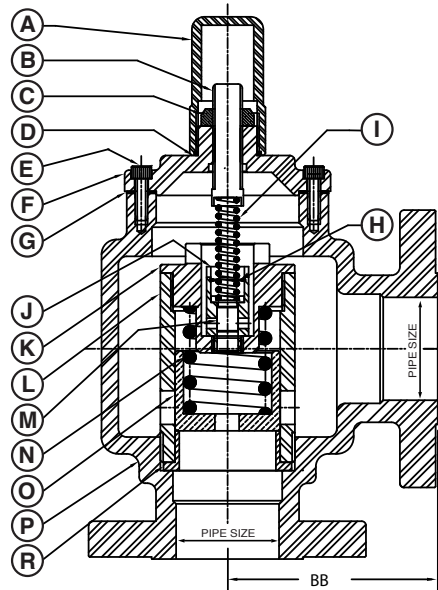

DIMENSIONS IN INCHES

Valve Size	Flange Rating	AA	BB
2½	150# 300#	15 ⁷ / ₈	5 ³ / ₄
2½	600#	16 ¹ / ₄	6 ¹ / ₈
3	150# 300#	16 ¹ / ₈	6 ¹ / ₄
3	600#	16 ¹ / ₂	6 ⁵ / ₈
4	150# 300#	18 ³ / ₁₆	7 ¹⁵ / ₁₆
4	600#	18 ³ / ₈	8 ¹ / ₈

PARTS LIST

Symbol	NAME	VALVE SIZE			
		MODEL	2½"	3"	4"
A	Cap	AA, AC ASS	A1101CR A1101SSR	A1101CR A1101SSR	A1101CR A1101SSR
B	Adjusting Screw	AA, AC ASS	A1102C A1102SS	A1102C A1102SS	A1102C A1102SS
C	Lock Nut	AA, AC ASS	505-S 505-SS	505-S 505-SS	505-S 505-SS
D	O-Ring †	AA, AC, ASS	604-*	604-*	604-*
E	Cap Screw		3/8 x 1 SHCS	3/8 x 1 SHCS	3/8 x 1 SHCS
F	Bonnet Cast Iron Steel Stainless Steel	AA AC ASS	A0919A A0919C A0919SS	A1019A A1019C A1019SS	A1119A A1119C A1119SS
G	Gasket †	AA, AC ASS	A0903E A0903RT	A1003E A1003RT	A1103E A1103RT
H	Retainer Ring †	AA, AC ASS	A1120D A1120SS	A1120D A1120SS	A1120D A1120SS
I	Pilot Spring †	AA, AC, ASS	A1190D	A1190D	A1190D
J	Piston Retainer †	AA, AC ASS	A1118C A1118SS	A1118C A1118SS	A1118C A1118SS
K	Cylinder Retainer	AA, AC ASS	A0912C A0912SS	A1012C A1012SS	A1112C A1112SS
L	Cylinder †	AA, AC ASS	A0928C A0928SS	A1028C A1028SS	A1128C A1128SS
M	Pilot Piston † Hardened Steel 416 Stainless-Steel 303 Stainless-Steel	AA, AC AA, AC ASS (Only)	A1115C A1115D A1115SS	A1115C A1115D A1115SS	A1115C A1115D A1115SS
N	Balance Spring †	AA, AC, ASS	A0980D	A1080D	A1080D
O	Piston † Hardened Steel 416 Stainless-Steel 303 Stainless-Steel	AA, AC AA, AC ASS (Only)	A0936C A0936D A0936SS	A1036C A1036D A1036SS	A1136C A1136D A1136SS
P	Body	AA AC ASS	A0900AF A0900CF A0900SSF	A1000AF A1000CF A1000SSF	A1100AF A1100CF A1100SSF
R	Retaining Bushing	AA, AC ASS	A0911C A0911SS	A1011C A1011SS	A1111C A1111SS

* See o-ring selection chart † Recommended spare parts

A-SERIES PERFORMANCE CHARTS

(Internal Pilot Operated)

All valve tests 110°F. to 120°F. Oil Viscosity 150 S.S.U. at 100°F.
(Charts good from 30 to 500 S.S.U.)

2 1/2" VALVE TESTS

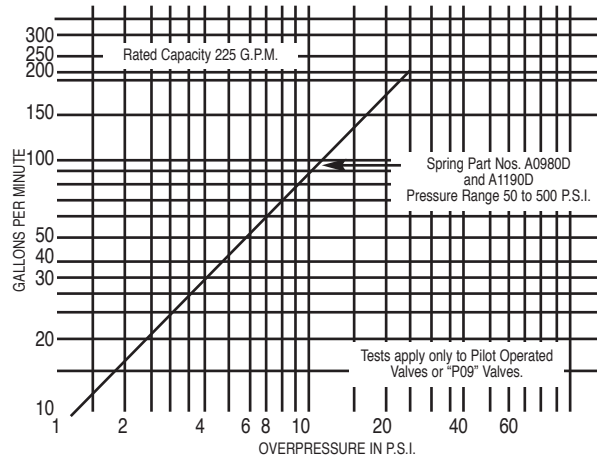

3" VALVE TESTS

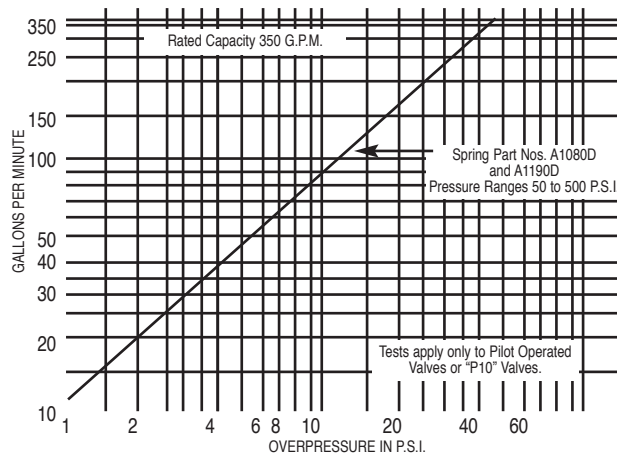

4" VALVE TESTS

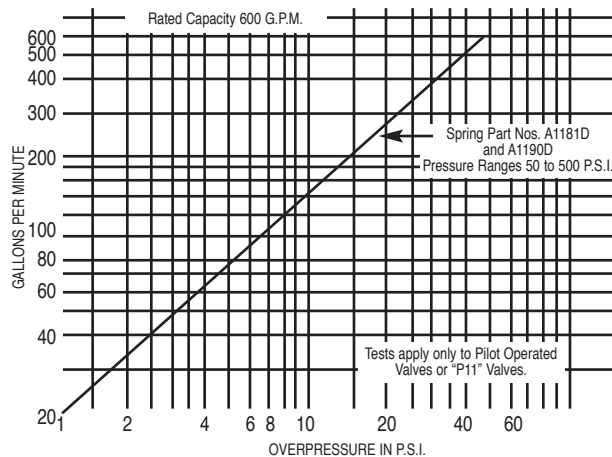

Overpressure - The pressure increase or accumulation above the set pressure when the valve is discharging flow.