

A-Frame Hose (AFH) Loader

OPW A-Frame Hose (AFH) Loading Arms offer the same advantages as conventional A-Frame Loaders, except flexible hose is used instead of rigid piping on secondary/outboard arm. The A-Frame's compact storage envelope allows loaders to be installed relatively close together, often on risers that are approximately the same height as the truck connection.

AFH loaders are typically stored in an upright, near vertical position, making it possible to load from both sides of a loading bay. In addition to bottom-loading petroleum, the AFH is also a common choice for use as a vapor recovery arm.



Features:

- 790 EZ Adjust Torsion Spring (3-Year Warranty)
- Integral Upward, Downward Travel Stops
- Carbon Steel/Aluminum Construction
- Low Temperature Fluorocarbon Seals
- Braided Stainless Steel or Rackmaster Composite Hose
- Available in Left-Hand, Right-Hand, Upfeed, Downfeed Configurations
- 360° Rotation Allows Loading on Both Sides of Loading Bay

Benefits

- Low Riser Mounting Height (typically same as truck connection)
- Compact Storage Envelope (nearly vertical)
- Easily Configured as Vapor Recovery Loader
- Can be Configured with Additional Swivel Plane for Added Flexibility



A-Frame Hose (AFH) Loader

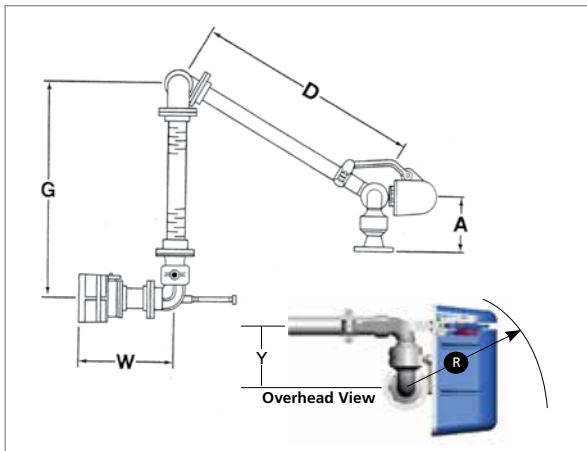

Dimensions*

Size		A		D		G	
in.	mm	in.	mm	in.	mm	in.	mm
3	76	10 ^{-1/2}	267	60	1524	72	1829
4	102	11 ^{-3/4}	298	60	1524	72	1829

W		R		Y	
in.	mm	in.	mm	in.	mm
21	533	18 ^{-1/2}	470	10 ^{-3/4}	273
21	533	20	508	12 ^{-3/4}	324

*Custom dimensions also available

Specifications

Materials	Carbon Steel/Aluminum
Seals	Low Temp Fluorocarbon
Working Pressure	125 psi (862 kPa)
Test Pressure	188 psi (1296 kPa)
Operating Temp	-20° to 140°
Up/Down Angular Movement	+80° to +45° (from horizontal)
Typical Horizontal Spacing	26" (660 mm)
Typical Vertical Spacing	15" (381 mm)
Typical Reach (radius)	45" to 60" (1143 mm to 1524 mm)
Typical No. of arms per bay	up to 4

Distributed by:

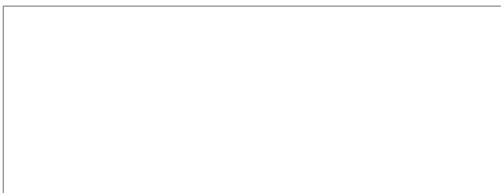

Accessories

Drop Spool	4" Aluminum or Carbon Steel	As Required
Drop Hose	4" Rackmaster Composite, 60" OAL, TTMA Flanged Ends	L19082
	4" Braided Stainless Steel, 60" OAL, TTMA Flanged Ends	L19083
Coupler Swivel	4" Style 30 (90°) Swivel Joint with Maneuvering Handle TTMA Flanged ends, Aluminum/ Low Temp Fluorocarbon	3635FTH-0402
Butterfly Valve	4" Full flow, Position-Locked Butterfly Valve	LBV450VGL
Spacer Spool	4" Loading Arm Coupler Spool, TTMA Flanged Ends, Aluminum 6" OAL	VSS4
Sight Glass	4" Acrylic Sight Glass, Tempered, Cast Acrylic	BF4-SG-25
API Coupler	4" API Bottom Loading Coupler	
	Manual Version:	1004D3-0402 (Fluorocarbon Seals)
	Semi-Automatic Version:	LYNX852 (Fluorocarbon Seals)

Ordering Information

AFH32F - 52 - 0402 - RH

Loading Arm Type

AFH = A-Frame
Hose

Feed

32 = Upfeed
33 = Downfeed

Reach

52 = 52" (1321 mm)
60 = 60" (1524 mm)
70 = 70" (1778 mm)

Seal Type

02 = Fluorocarbon

Size

04 = 4"

Orientation

RH = Right Hand
LH = Left hand