

94210

Emergency Vent & Manhole Cover (Hinged)

SHAND & JUR'S

94210 Emergency Vent & Manhole Cover (Hinged)

The Shand & Jurs 94210 Emergency Vent and Manhole Cover is an economical solution to emergency venting requirements where intermediate pressure settings are required.

The design of Model 94210 employs a flexible diaphragm affording a tight seal between the pallet and the corrosion resistant seat below set pressure. This also assures low leakage. The diaphragm is intended for normal ambient temperature storage. Special diaphragms for tanks storing products other than oils and gasoline are available.

When set pressure is achieved, the pallet starts to lift. Flow efficiency rises rapidly to approximately 60% of a perfect orifice at 40% excess of the set pressure. At higher overpressure the flow efficiency approximates 75%.

For tank venting or examination, the entire hinged cover may be lifted open in a matter of seconds, offering clear passage through the unobstructed opening. Since no gasket replacement or unbolting is necessary, this vent eliminates the expensive manpower needed to put conventional emergency vents back in operation.

Pallet construction permits a wide variety of pressure settings. See specifications for various pressure settings of all vent sizes.

Standard design is available in 8", 10", 12", 16", 18", 20", 24", 30" and 36" sizes. The Standard Mounting Flange is 150lb. ANSI Flat Face. The body has three lifting ears that are used to raise and position the unit. This helps to protect the internal diaphragm during installation. Lifting ears are not available on 8", 10" and 12" sizes. The 20" and 24" vents can be provided with flat face flanges to fit API 650 Roof Manholes. Special construction types are also available.

Expanda-Seal

Shand & Jurs "Expanda-Seal" option is available on all pressure pallet assemblies. This feature significantly reduces leakage. The ballooning effect of the Teflon diaphragm effectively seals the valve.

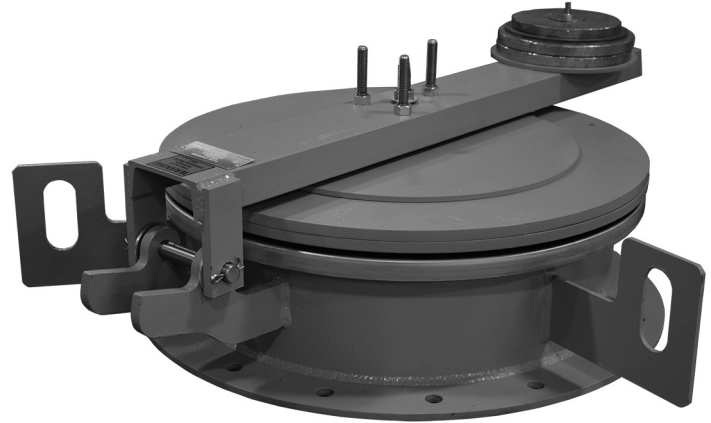
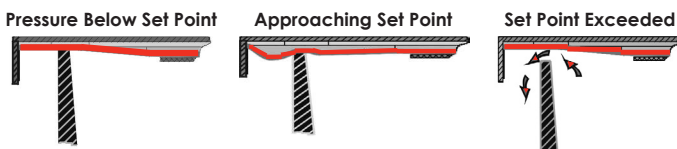

Features

- Easy installation and handling for inspection
- Tank examination requires no gasket replacement or unbolting
- 8", 10", 12", 16", 18", 20", 24", 30" and 36" base designed to fit 150 lb. ANSI flange
- 20" & 24" flange sizes also designed to fit API 650 flange
- EN1092 sizes available
- Materials of construction include Aluminum, Steel & 316 Stainless Steel
- Limit Switches available

SHAND & JUR'S

5911 Butterfield Road Hillside, IL 60162 • tel: (708) 236-6000 • fax: (708) 236-6006
sales@ljtechnologies.com • www.ljtechnologies.com • ISO 9001: 2015 Certified

Rev: 94210-3H

Specifications

Size	8"	10"	12"	16"	18"	20"	24"	10"	12"	16"	18"	20"	24"	30"	36"	
Type	Low Setting							High Setting							C.F.	C.F.
Pressure Settings	Standard	1.0 oz/in ²	1.1 oz/in ²	1.2 oz/in ²	1.3 oz/in ²		1.5 oz/in ²	> 4.0 oz/in ²							C.F.	C.F.
	Minimum	1.0 oz/in ²	1.1 oz/in ²	1.2 oz/in ²	1.3 oz/in ²		1.5 oz/in ²	> 4.0 oz/in ²							C.F.	C.F.
	Maximum	4.0 oz/in ²							20 oz/in ²			16 oz/in ²		C.F.	C.F.	

Standard Materials of Construction

Base	Aluminum	Steel	316 Stainless Steel
Pallet	Aluminum	316 Stainless Steel	316 Stainless Steel
Seat	Aluminum	Stainless Steel Overlay	316 Stainless Steel
Load Weight(s)	Steel / Lead	Steel / Lead	Lead
Hardware	316 Stainless Steel	316 Stainless Steel	316 Stainless Steel
Hinge Arm	Steel	Steel	316 Stainless Steel
Hinge Pin	Stainless Steel	Stainless Steel	Stainless Steel
Diaphragm	FEP	FEP	FEP

Alternate materials of construction available. Consult Factory.

Dimensions

Vent Size	Connection Matching Size	"A"	"B"	"C"	Diameter "D"	Diameter "E"	Diameter "F"	Diameter "G"	"H"	"K"
8"	8" ANSI Class 150	18 ¹³ / ₁₆	9 ¹³ / ₁₆	9	11 ³ / ₄	13 ¹ / ₂	8	⁷ / ₈	8	8 ¹ / ₁₆
10"	10" ANSI Class 150	20 ¹³ / ₁₆	11 ¹³ / ₁₆	10	14 ¹ / ₄	16	10	1	12	10 ¹ / ₁₆
12"	12" ANSI Class 150	24	13 ¹ / ₂	10	17	19	12	1	12	12
16"	16" ANSI Class 150	28 ⁹ / ₁₆	16 ¹ / ₂	10	21 ¹ / ₄	23 ¹ / ₂	16	1 ¹ / ₈	16	14
18"	18" ANSI Class 150	37 ¹ / ₁₆	20 ¹³ / ₁₆	12 ¹ / ₈	22 ³ / ₄	25	18	1 ¹ / ₄	16	17 ¹⁵ / ₁₆
20"	20" API Roof Manhole	37 ¹ / ₁₆	20 ¹³ / ₁₆	12 ¹ / ₈	23 ¹ / ₂	26	20	³ / ₄	16	17 ¹⁵ / ₁₆
20"	20" ANSI Class 150	37 ¹ / ₁₆	20 ¹³ / ₁₆	12 ¹ / ₈	25	27 ¹ / ₂	20	1 ¹ / ₄	20	17 ¹⁵ / ₁₆
24"	24" API Roof Manhole	41 ⁵ / ₁₆	22 ¹³ / ₁₆	12 ¹ / ₄	27 ¹ / ₂	30	24	³ / ₄	20	20 ¹ / ₁₆
24"	24" ANSI Class 150	41 ⁵ / ₁₆	22 ¹³ / ₁₆	12 ¹ / ₄	29 ¹ / ₂	32	24	1 ³ / ₈	20	20 ¹ / ₁₆
30"	30" ANSI Class 150	50 ¹ / ₈	26	18 ¹ / ₄	36	38 ³ / ₄	30	1 ³ / ₈	28	23 ³ / ₄
36"	36" ANSI Class 150	71 ⁷ / ₁₆	31 ³ / ₁₆	13 ³ / ₄	42 ³ / ₄	46	36	1 ⁵ / ₈	32	27 ⁹ / ₁₆

All designs subject to change. Certified dimensions and specifications available upon request.

94210 Ordering Guide

Model Number Selection

The model number will consist of a base number **94210** followed by 6 digit numbers. These digits will represent 4 option tables.

94210 - AB - CD - EF

Ordering Information

Specify:

1. Model 94210 Emergency Vent / Manhole Cover
2. Size Required
3. Base and Cover Material
4. Pressure Setting
5. Tank Product and Temperature
5. ANSI or API Base
6. Seal Type Standard or Expanda-Seal
7. CE for Ordinary EU Locations specify Table E, Option 1
8. ATEX Certification for Group IIB, IIA EU Locations, specify Table E, Option 2

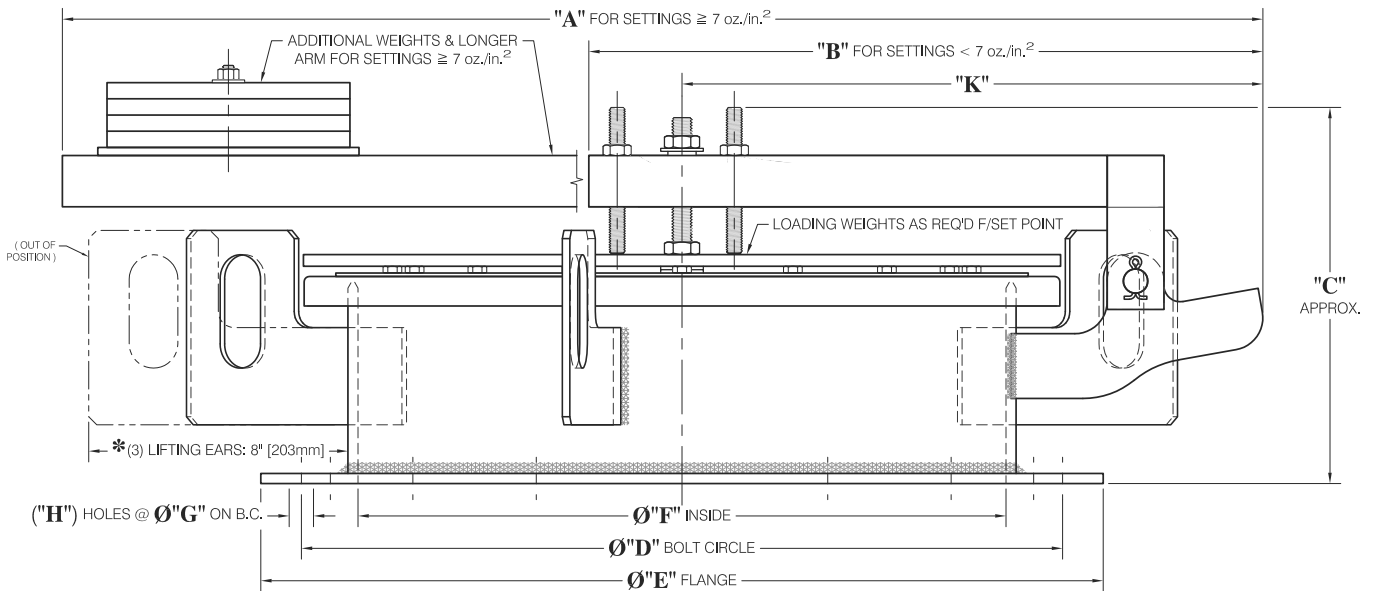
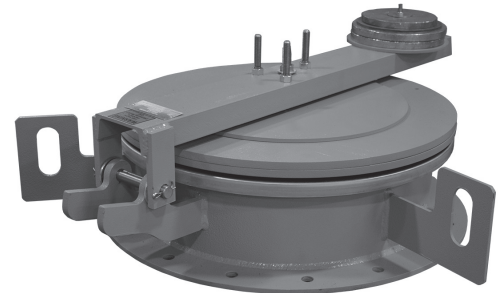

* (3) EARS SPACED APPROX. EQ'LY BETWEEN FASTENERS; NOT INCLUDED ON ALL SIZES.

Lifting Ears not available on 8", 10", and 16" sizes.

Table AB - Size & Material

Size (Inches)	Base	Flange	
		Option AB	Option AB
		ANSI*	API 650
8"	Steel	08	N/A
8"	316 Stainless Steel	09	N/A
8"	Aluminum	10	N/A
10"	Steel	11	N/A
10"	316 Stainless Steel	15	N/A
10"	Aluminum	21	N/A
12"	Steel	27	N/A
12"	316 Stainless Steel	28	N/A
12"	Aluminum	29	N/A
16"	Steel	12	N/A
16"	316 Stainless Steel	16	N/A
16"	Aluminum	22	N/A
18"	Steel	19	N/A
18"	316 Stainless Steel	26	N/A
18"	Aluminum	25	N/A
20"	Steel	33	13
20"	316 Stainless Steel	37	17
20"	Aluminum	43	23
24"	Steel	34	14
24"	316 Stainless Steel	38	18
24"	Aluminum	44	24
30"	Steel	35	N/A
30"	316 Stainless Steel	39	N/A
30"	Aluminum	45	N/A
36"	Steel	36	N/A
36"	316 Stainless Steel	40	N/A
36"	Aluminum	46	N/A

* Flat Faced ANSI Hole Pattern Only.
For a Raised Faced ANSI flange connection, Consult Factory.

Table E - CE or ATEX

Option E	Description
0	Standard
1	CE
2	ATEX Certification

Table F - Seal Type

Expanda-Seal Option F	Standard Option F
1	0

Table CD - Pressure Setting

Valve Size	Option CD	Settings (oz/in ²)	
		Standard	Maximum*
8"	01	1.0	1.0
10"		1.1	1.1
12"		1.2	1.2
16"		1.3	1.3
18"		1.3	1.3
20"		1.3	1.3
24"		1.5	1.5
30"		1.7	1.7
36"		1.9	1.9
8"		02	Above Standard Setting to 4 oz/in ²
10"			
12"			
16"			
18"			
20"			
24"			
30"			
36"			
8"	11		
10"			
12"			
16"			
18"			
20"			
24"			
30"			
36"			
8"		12	> 8 oz.
10"			
12"			
16"			
18"			
20"			
24"			
30"			
36"			

* Consult Factory for settings greater than shown.