

## 94040 Spring Loaded Conservation Vent

The Shand & Jurs Model 94040 Spring Loaded Conservation Vent is designed utilizing over 80 years of experience in producing high quality and dependable conservation vents and safety fittings. This vent meets the need of higher pressure settings required on storage tanks (ideally suited when blanketed with nitrogen or other inert gas), process vessels and piping common to the petroleum, chemical and petro-chemical industries.

Higher pressure settings are accommodated using a unique method of spring loading which ensures highly reliable operation and reduces excessive venting of product at a relatively low cost. Pressure settings range from 1 psig through 15 psig for all sizes except 12" which has a maximum of 12 psig. Screw and flange type connections are offered for the 2" and 3" size and flange only for sizes 4" to 12". Vacuum protection is provided utilizing a weight loaded vertical lift pallet assembly that assures optimum air flow into tank.

The pallet to seat diaphragm is cushion seated Teflon for long service life and optimum reliability. This diaphragm helps to ensure a high resistance to any ice and gum formations, prevents the pallet from sticking to the seat. The carefully engineered body, seat and pallet offers a superior combination of tight sealing and high capacity at lower over-pressure.

An Expanda-Seal is available on the pressure pallet to assure minimal leakage up to 95% of set pressure.

One of the most important features which should be noted in the Model 94040 design is the variety of construction materials available. A wide range of highly corrosive and toxic products common to the petroleum, petro-chemical and chemical industries, require that a conservation vent be able to withstand this environment and still function reliably. For few instances where our standard materials may not be suitable, optional materials are readily available.

Standard materials offered are aluminum, cast iron, cast steel and 316 stainless steel. Standard seats are aluminum and 316 stainless steel.

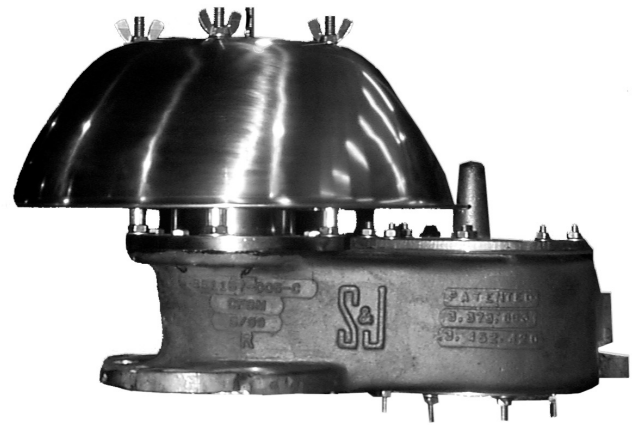

### Features

- Low copper aluminum alloy minimizes special materials needs
- Guided pressure pallet assures smooth lift and closure
- Unique diaphragm construction assures positive seal and minimal blowdown
- Easy inspection of internal components
- Withstands variety of materials including highly corrosive and toxic products
- Pallet lip design contributes to high flow characteristics

# 94040

## Spring Loaded Conservation Vent



### Specifications:

**Sizes:**

2", 3", 4", 6", 8", 10" &amp; 12"

**Pressure:**

Minimum 1 psig

**Vacuum:**2 oz/in<sup>2</sup> (3.46 in. w.c.)**Maximum Pressure Setting\*:**

2"-10" - 15 psig; 12" - 12 psig

**\*Max. Standard Vacuum Setting (oz/in<sup>2</sup>):**

Size	Lead Weights	Stainless Steel Weights
2"	7.5 oz.	6 oz.
3"	9 oz.	7.5 oz.
4"	10.5 oz.	7.5 oz.
6"	12 oz.	7.5 oz.
8"	13.5 oz.	9 oz.
10"	16.5 oz.	12 oz.
12"	21 oz.	15 oz.

Higher settings may be available. Consult Factory.

**Temperature Range: Body and Seal**Options for Process Temperature Ranges of  
-50°F to 220°F (Stainless Steel and Aluminum)

-20°F to 220°F (Steel)

**Service and Body Material:****Normal:**

Cast Low Copper Aluminum

**Severe:**

Steel, Cast Iron, 316 Stainless Steel

**Pressure Seat:**

Aluminum or 316 Stainless Steel

**Vacuum Integral Seat:**

Same as body; Aluminum, 316 SS, Cast Steel with 316 SS overlay

**Hood (Open Vent):**

Stainless Steel, Aluminum, 316 Stainless Steel

**Type of Flange Connection:**

Screwed or flanged for 2" &amp; 3" sizes

Flanged for 4", 6", 8", 10" &amp; 12" sizes

Raised Face flange available, except for aluminum body material. Flange connection matches vent size 150 lb. ANSI compatible.

### Dimensions:

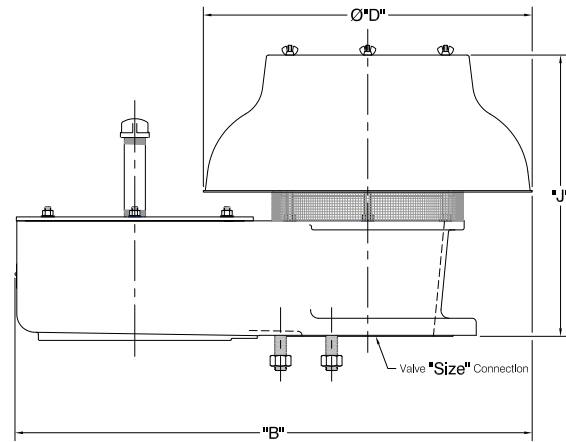
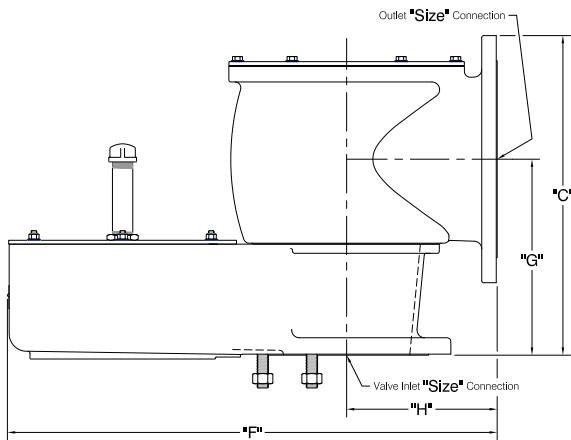

Vent Size	Outlet Size	"F"	"C"	"G"	"H"
2"	3"	13	10 3/8	5	4 1/4
3"	4"	16 3/16	12 1/8	5 15/16	5 1/4
4"	6"	19 1/4	14 1/8	7	5 15/16
6"	8"	26 1/8	17 1/4	10 5/16	8 1/4
8"	10"	31 7/8	20 7/8	12 11/16	9 3/4
10"	12"	38 1/8	24 5/8	14 7/8	11 19/32
12"	14"	43 3/8	27 5/8	16 7/8	12 13/16

Inlet size = Outlet size available. Consult Factory for dimensions.

Vent Size	"B"	"J"	Diameter "D"
2"	15 1/4	10 3/4	12 7/8
3"	17 15/16	11 9/16	13 9/16
4"	21 1/2	13 5/8	15 15/16
6"	26	14 7/8	18 5/8
8"	29 25/32	16 3/4	18 5/8
10"	37 7/16	18 1/2	25 1/16
12"	43 15/16	21 1/8	29 7/8

All designs subject to change. Certified dimensions and specifications available upon request.

5911 Butterfield Road Hillside, IL 60162 • tel: (708) 236-6000 • fax: (708) 236-6006  
sales@ljtechnologies.com • www.ljtechnologies.com • ISO 9001: 2008 Certified

Rev: 94040-3C

## 94040 Ordering Guide

### Model Number Selection

The model number will consist of a base number **94040** followed by 8 digit numbers. These digits will represent 4 sets of option tables.

**94040 - AB - CD - EF - GH**

### Ordering Information

Specify:

1. Model 94040 Spring Loaded Conservation Vent
2. Size
3. Pressure and Vacuum Setting
4. Type of Seat
5. Temperature Range
6. Type of Service and Body Material
7. Type of Flange Connection
8. Seal Type
9. To Specify CE for Ordinary EU Locations use Table G2
10. ATEX Certification for Group IIB, IIA EU Locations use Table G

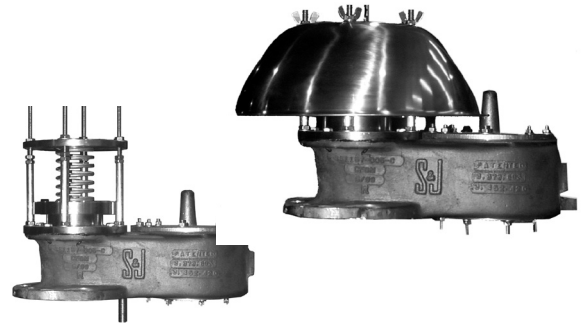

**Table CD - Pressure Setting Ranges (PSIG)**

Option CD	Range From	Range To
01	1.0	2.0
02	2.1	3.0
03	3.1	4.0
04	4.1	5.0
05	5.1	6.0
06	6.1	7.0
07	7.1	8.0
08	8.1	9.0
09	9.1	10.0
10	10.1	11.0
11	11.1	12.0
12	12.1	13.0
13	13.1	14.0
14	14.1	15.0

ATEX and CE Models are Limited to Options 01-06.

12" Size Maximum Set Point 12 PSIG

**Table EF - Flange Type & Seal Material**

Option EF	Description
0X	ANSI 125/150lb. FF
1X	ANSI 125/150lb. RF*
2X	EN1092 PN 16 FF
3X	EN1092 PN 16 RF*
4X	JIS 10K FF
5X	JIS 10K RF*
X0	FEP/N8090
X1	PTFE**
X2	Buna
X3	Viton
X4	All Teflon

\* RF Not Available in Aluminum

\*\* PTFE Expanda-Seal not available

**Table GH - Seal Type & Trim**

Option GH	Description
00	Standard / SS
01	Expanda-Seal / SS
*10	ATEX Certified / 316 SS
*11	ATEX Certified Expanda-Seal / 316 SS
20	CE Standard Seal / SS
21	CE Expanda-Seal / SS
**30	Standard / 316 SS
**31	Expanda-Seal / 316 SS

\* Pallet, Side Guides, Nuts, Bolts, Screen and Spring are 316 Stainless Steel (ATEX Only - Max. Set Pressure 7 PSIG).

\*\*Pallet, Side Guides, Nuts, Bolts, Screen and Spring are 316 SS

**Table AB - Size, Material, Configuration & Flange**

Option A	Materials: Body, Trim	Vent Type	CV Type
1	Aluminum, SS	Open, FF	-
2	Aluminum, SS	Closed, FF	Outlet > Inlet
3	Cast Iron, SS	Open, FF	-
4	Cast Iron, SS	Closed, FF	Outlet > Inlet
5	Cast Iron, SS	Closed, RF	Outlet > Inlet
6	Steel, SS	Closed, FF	Outlet > Inlet
7	Steel, SS	Closed, RF	Outlet > Inlet
8	316 SS, 316 SS	Closed, FF	Outlet > Inlet
9	316 SS, 316 SS	Closed, RF	Outlet > Inlet
A	Cast Iron, SS	Open, RF	-
B	Steel, SS	Open, FF	-
C	Steel, SS	Open, RF	-
D	316 SS, 316 SS	Open, FF	-
E	316 SS, 316 SS	Open, RF	-
F	Aluminum, SS	Closed, FF	Outlet = Inlet
G	Cast Iron, SS	Closed, FF	Outlet = Inlet
H	Cast Iron, SS	Closed, RF	Outlet = Inlet
I	Steel, SS	Closed, FF	Outlet = Inlet
J	Steel, SS	Closed, RF	Outlet = Inlet
K	316 SS, 316 SS	Closed, FF	Outlet = Inlet
L	316 SS, 316 SS	Closed, RF	Outlet = Inlet

Trim includes: Stem, Stem Guide, Side Guides, Nuts, Bolts, Screen.

SS - Stainless Steel

302 SS Spring as Standard (Other material available depending on set point 316 SS (lower SP) or 17-7PH (higher SP)).

Option B	Size
2	2"
4	3"
5	4"
6	6"
7	8"
8	10"
9	12"