

30 SERIES LEVEL SWITCHES

One-float level switch for top mounting with one or two switching units. For pressure up to 50 Bar, for temperatures up to 400°C max. and for fluids with a specific gravity of 0.6 kg/dm³ min. Minimum differential of each switch with SP.GR. of 1 kg/dm³, 30 mm. Set point accuracy: ± 5 mm.

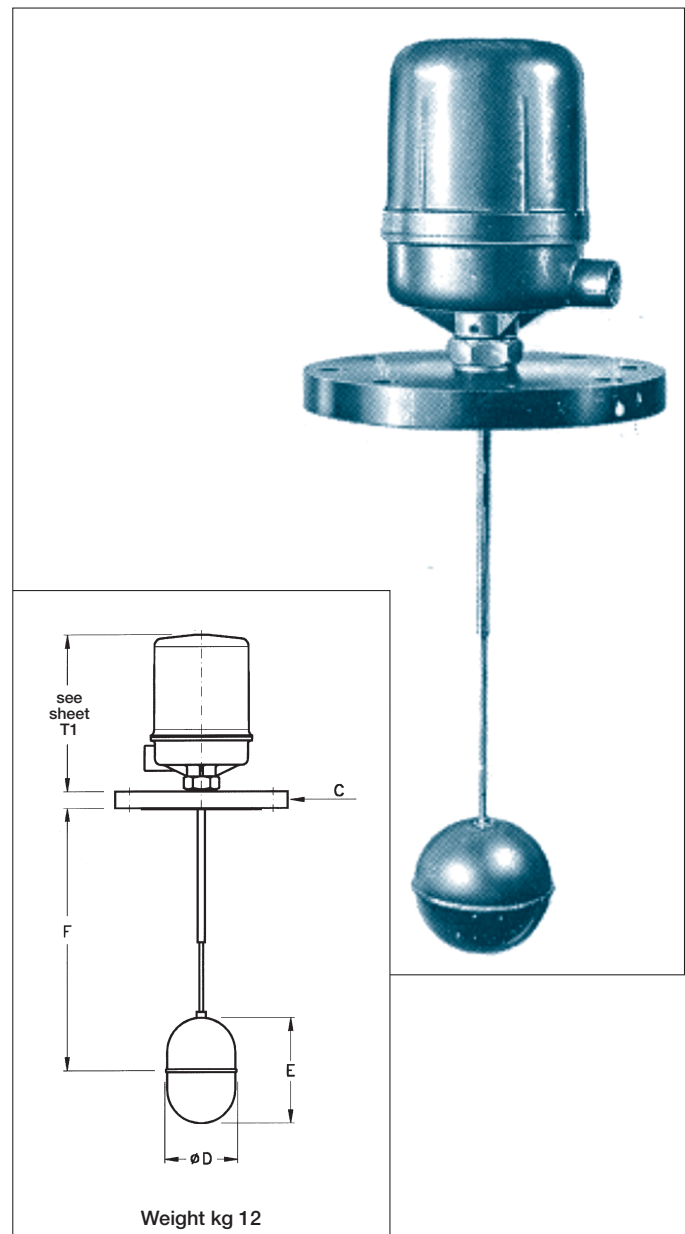
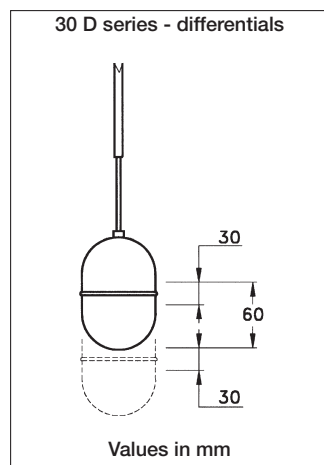
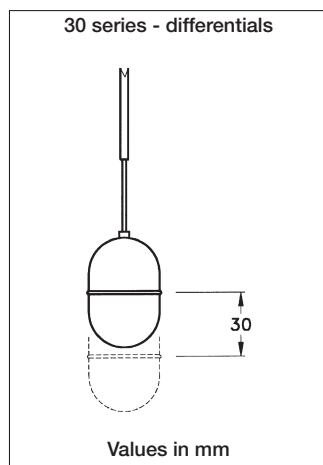
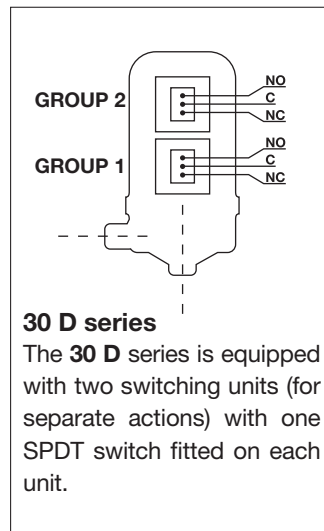
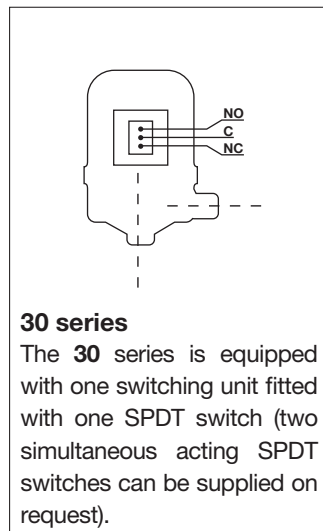

In the following table is shown the maximum possible F length in relation to the type of standard float available and to the various specific gravity of the fluid to be checked.

FLOATS			MINIMUM SPECIFIC GRAVITY OF FLUID kg/dm ³											STD "C" Flange connection	
ø D	E		1.6	1.5	1.4	1.3	1.2	1.1	1	0.9	0.8	0.7	0.6	ANSI	UNI
*68	120	F (mm)	1300	1300	1300	1300	1000	700	380	-	-	-	-	3"	DN 80
94	90	F (mm)	1300	1300	1300	1300	1300	1100	910	-	-	-	-	4"	DN 100
94	140	F (mm)	1300	1300	1300	1300	1300	1300	1300	1300	1150	-	-	4"	DN 100
94	180	F (mm)	1300	1300	1300	1300	1300	1300	1300	1300	1300	1300	670	4"	DN 100

* Max. pressure rating 40 Bar.

For equipment with one switching unit and fins or double switching unit, the F length is to be reduced by 300 mm.

For equipment with double switching unit and fins, the F length is to be reduced by 750 mm.

For temperatures exceeding 135°C or below -10°C, fins with the "R" code are fitted on all versions; temps. of 135-250°C, R1; 250-400°C, R4; -10- 80°C R3

On request, the threaded connection 2" NPT - M, 3" NPT - M and 3/4" GAS can be supplied.

WORKING CONDITIONS

MODEL		32			34			36		
STD "C" FLANGE		3"- 4" ANSI 150 RF UNI DN 80-100 PN 16			3"- 4" ANSI 300 RF UNI DN 80-100 PN 40			4" ANSI 600 RF UNI DN 100 PN 64		
VERSION		A	I	J	A	I	J	A	I	J
Temperatures	100° C	17	15	16	35	30	31	46	40	42
	150° C	15	13	14	34	27	29	45	36	38
	200° C	13	12	13	33	25	27	43	32	35
	250° C	11	11	11	32	23	25	41	30	33
	300° C	10	10	10	29	22	24	38	28	31
	350° C	8	8	8	28	21	23	36	28	30
	400° C	6	6	6	27	21	22	34	27	29
BODY RATING		ANSI 150			PN 40			ANSI 300		

Max pressure in bar

MATERIALS

CODE FOR:	Materials	Carbon steel	AISI 304	AISI 316
	Body	A	I	J
	Float	-	-	2

On request, versions in plastic (PVC - MOPLN - PVDF) can be supplied.

SWITCHES

Type	Mercury switch	Dry microswitch					Pneumatic switch*
Load rating	220 V a. c. 10 A 110 V d. c. 1,5 A	250 V a. c. 10 A 125 V d. c. 0,5 A	125 V d. c. 10 A	250 V a. c. 10 A 125 V d. c. 0,5 A waterproof	125 V a. c. 1 A 28 V d. c. 1 A waterproof with gold contacts	250 V a. c. 1A 24 V d.c. 3A sealed with inert gas	Output: 0 ÷ 40 psi max.
CODE	VD	M2	M3	M4	M6	M14	PNA (aluminium)

*Air inlet and output connection 1/4" NPT-F - No bleed type

ENCLOSURES

Type	Waterproof	Explosion-proof	The (WP) enclosures can be supplied whit gland or with a 3 or 7 pole connector as per MIL standards. The (EP) enclosures can be supplied whit explosion-proof gland. 1) CESI certificate N. 02-ATEX-126
Material	Aluminium	Aluminium	
Connection	1/2" NPT-F/GAS 3/4" NPT-F/GAS ISO M20x1.5	1/2" UNI 6125/NPT-F 3/4" UNI 6125/NPT-F ISO M20x1.5	
Protection degree	IP 66	ATEX II 2 G Ex d IIC T6 o T5 Gb ATEX II 1/2 D Ex ta/tb IIIC T85° o T100° C Da/Db IP 66	
CODE	WP	EP	

HOW TO ORDER

Example: 32 - A - 2 - M2 - WP - R1

- 32 model
- A body in carbon steel
- 2 float in S/steel AISI 316
- M2 dry switch. 250 V a.c. - 10 A
- WP waterproof enclosure
- R1 cooling fins (t 200° C); optional

The following data are required: type of fluid, specific gravity, operating temperature and pressure.