

108FC (Globe) / 108FCA (Angle)

Fire Pump Relief Valve

An automatic, pilot controlled, pressure relief valve actuated by the pipeline pressure. The valve modulates to maintain a steady, predetermined pressure in the network. Should the upstream pressure exceed the required set point, the valve opens, releasing the excessive pressure. When the pressure falls below the set value, the valve closes drip tight.

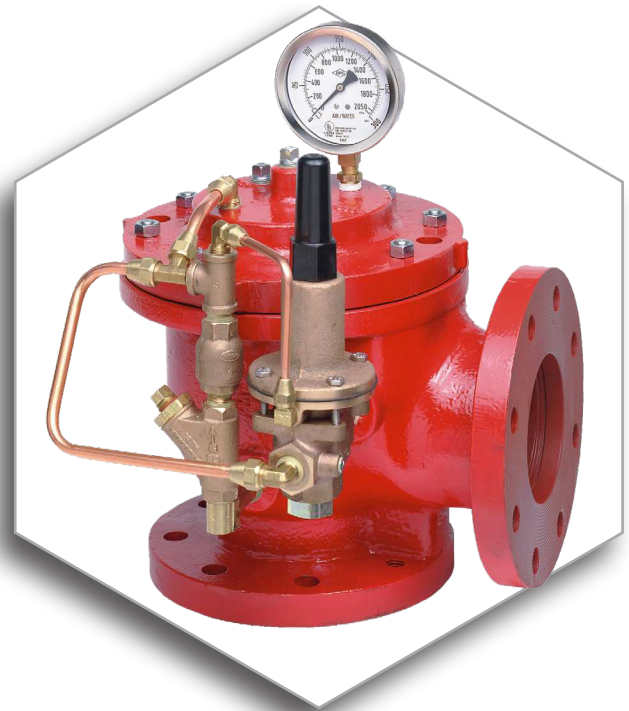

* General representation of valve

CERTIFICATION & COMPLIANCE



- ANSI FCI 70-2 Class VI seat leakage class
- UL listed under QXZQ category
- Factory Mutual Approved
- ABS type approval

FEATURES & BENEFITS

- Limits maximum pump discharge pressure
- Opens quickly; maintains pressure within close limits
- Adjustable: 60psi - 180psi (4.1 - 12.4 bar) or 100psi - 300psi (6.9 - 20.7 bar)
- Pilot operated main valve
- Simple field adjustable pressure setting, requiring no special tools or system down time
- Factory tested & preset to requirements
- UL listed & Factory Mutual Approved for both split case centrifugal & vertical turbine pumps
- Wide range of materials available
- Applicable for water, seawater & foam

TYPICAL APPLICATIONS



Pump & Water Tanks



Fire Suppression Systems



Petrochemical, Oil & Gas Installations



Tunnels



Power Generation, Transformer & Transmission Plants



Onshore / Offshore



Mining

OPERATION

The normally closed, spring loaded pilot, sensing pump discharge pressure, opens when pressure exceeds the spring setting, allowing the main valve to open. As the pump pressure increases the pilot controls the main valve to open further. Pressure is maintained at the controlled set point over a wide range of flows regardless of back pressure in the downstream piping. The valve closes gradually as pressures decrease below the set point.

The Model 108FC consists of the following components, arranged as shown on the schematic diagram:

- [1] **Model 65 Basic Control Valve (angle pattern shown)**, a hydraulically operated, diaphragm actuated, globe or angle valve which closes with an elastomer-on-metal seal.
- [2] **Model 1330FC Pressure Relief Pilot**, a 2-way, normally closed pilot valve which senses upstream pressure under its diaphragm and balances it against an adjustable spring load. An increase in upstream pressure tends to make the pilot open.
- [3] **Model 126 Ejector**, a “tee” fitting with a fixed orifice in its inlet port. It provides the proper pressure to the diaphragm chamber of the main valve, depending on the position of the pressure relief pilot.
- [4] **Model 141-1 Check Valve**, prevents the valve from opening under a vacuum condition that may occur with a vertical turbine pump.
- [5] **Model 159 Y-Strainer**, protects the pilot system from solid contaminants in the line fluid.
- [6] **Pressure Gauge**
- [7] **Model 155 Visual Indicator**, (optional) provides indication of the valve’s position at a glance.

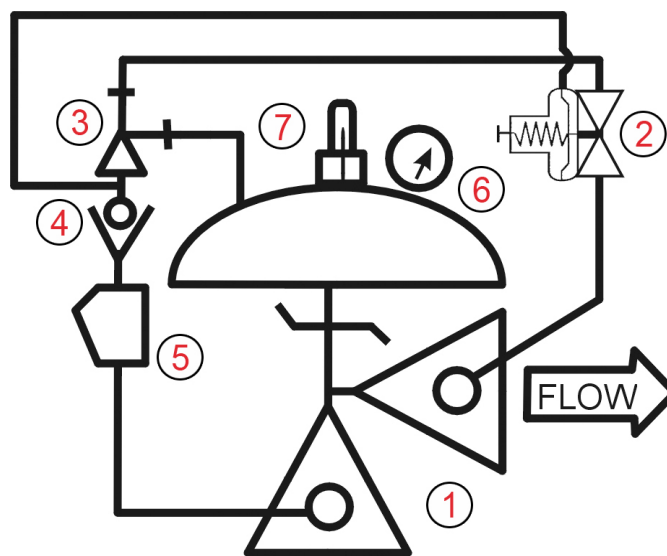

Resetting, maintenance and periodic testing instructions must be followed as described in detail in the applicable OCV IOM (Installation, Operation & Maintenance) Manual.

TYPICAL MATERIALS

Description	Standard	Optional
Valve Body	Ductile Iron	Cast Steel, Stainless Steel, NAB
Seat Ring	Bronze	Stainless Steel, NAB
Stem	Stainless Steel	Monel
Spring	Stainless Steel	----
Diaphragm	Buna-N	EPDM
Seat Disc	Buna-N	EPDM
Pressure Relief Pilot	Stainless Steel	NAB
Tubing / Fittings	Copper, Bronze/Brass	Stainless Steel

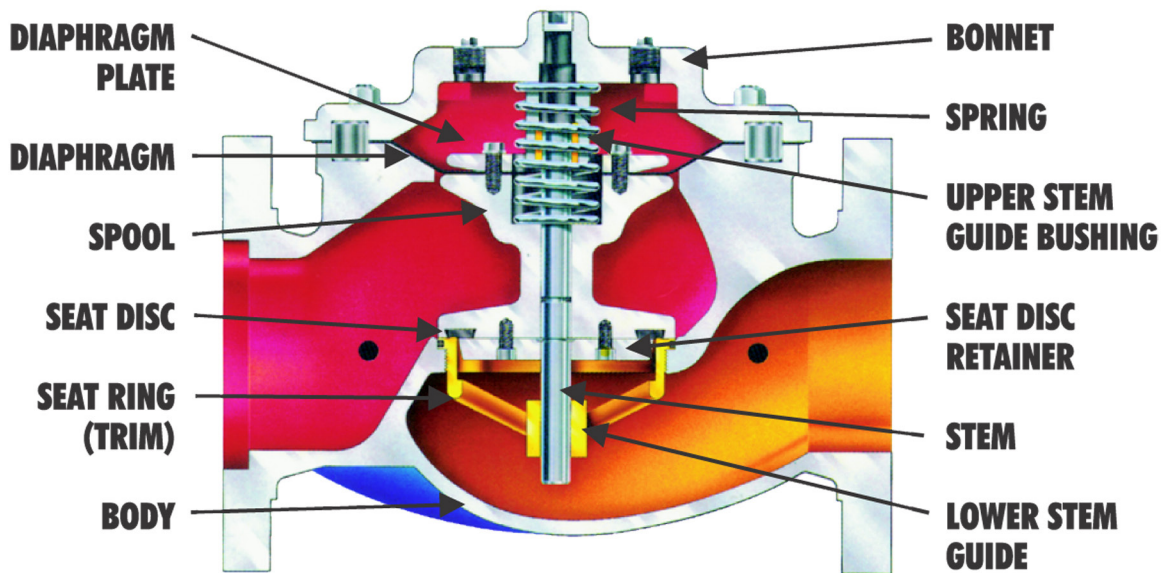

* General representation of valve

GENERAL ARRANGEMENT & DIMENSIONS

U.S. DIMENSIONS - INCHES

Valve DIM	FLANGES	3"	4"	6"	8"
A	150#	12	15	17 3/4	25 3/8
	300#	12 3/4	15 5/8	18 5/8	26 3/8
	300# x 150#	12 3/4	15 5/8	18 5/8	26 3/8
B	150#	3 3/4	4 1/2	5 1/2	6 3/4
	300#	4 1/8	5	6 1/4	7 1/2
	300# x 150#	4 1/8	5	6 1/4	7 1/2
C	150#	6	7 1/2	10	12 11/16
	300#	6 3/8	7 13/16	10 1/2	13 3/16
	300# x 150#	6 3/8	7 13/16	10	12 11/16
D	150#	4	5 1/2	6	8
	300#	4 3/8	5 13/16	6 1/2	8 1/2
	300# x 150#	4 3/8	5 13/16	6 1/2	8 1/2
E	ALL	6 1/2	8	10	11 7/8
F	ALL	3 7/8	3 7/8	3 7/8	6 3/8
G	ALL	8 3/4	11 3/4	14	21
H	ALL	11	12	13	14

* Approximate dimensions

METRIC DIMENSIONS - M.M.

Valve DIM	FLANGES	DN80	DN100	DN150	DN200
A	150#	305	381	451	645
	300#	324	397	473	670
	300# x 150#	324	397	473	670
B	150#	95	114	140	171
	300#	105	127	159	191
	300# x 150#	105	127	159	191
C	150#	152	191	254	322
	300#	162	198	267	335
	300# x 150#	162	198	254	322
D	150#	102	140	152	203
	300#	111	148	165	216
	300# x 150#	111	148	165	216
E	ALL	165	203	254	302
F	ALL	98	98	98	162
G	ALL	222	298	356	533
H	ALL	279	305	330	356

* Approximate dimensions

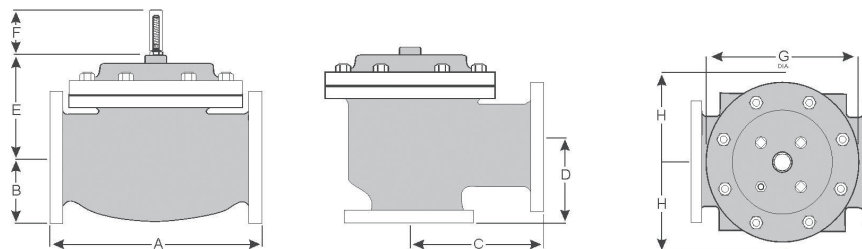

* General representation of valve

TYPICAL INSTALLATION

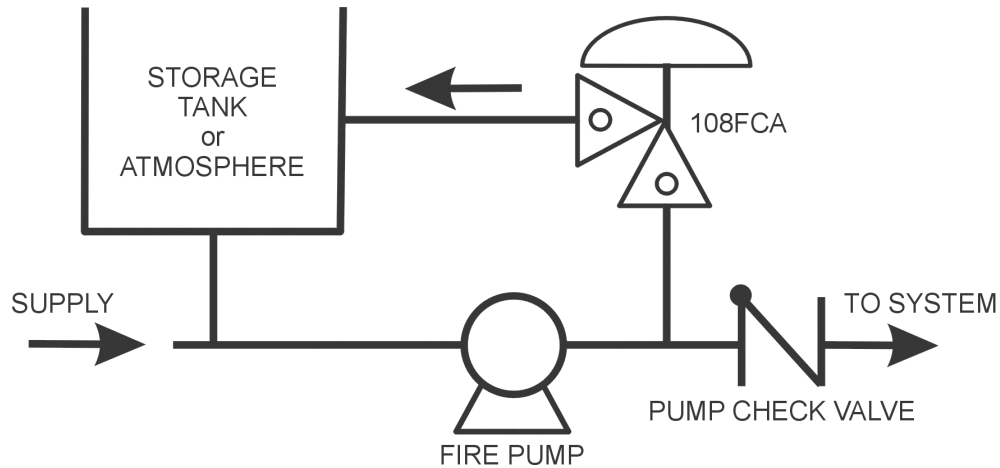

FLOW CHARACTERISTICS

Fire pump relief valves are sized per the guidelines in NFPA 20, and are based on the rated flow of the pump.

For more detailed sizing information, please contact OCV.

Valve Size	Max. Pump Flow, GPM	Max. Pressure Setting, PSI
3"	500	300 (UL) 175 (FM)
4"	1000	300 (UL) 175 (FM)
6"	2500	300 (UL) 175 (FM)
8"	5000	175 (UL & FM)

Valve Size	Max. Pump Flow, M ³ /HR	Max. Pressure Setting, BAR
DN80	114	20.7 (UL) 12.0 (FM)
DN100	227	20.7 (UL) 12.0 (FM)
DN150	568	20.7 (UL) 12.0 (FM)
DN200	1136	12.0 (UL & FM)

* Not all items pictured reflect products sold by OCV

TECHNICAL DATA

Temperature:

- Buna-N 32°F to 180°F
- EPDM 32°F to 230°F

Sizes:

- Globe or Angle: 3", 4", 6", 8"

End Connections:

- ANSI Flanged Class #150, Class #300, & 300 inlet x 150 outlet

Body and Cover Material:

- Ductile Iron
- Cast Steel
- Stainless Steel
- NAB

Trim Material:

- Bronze/Brass - Copper
- Stainless Steel
- Monel

Optional Components:

- Visual Indicator
- Pressure Switch

Items to Specify:

- Electrical features other than standard
- If explosion proof accessories are required, please define classification
- Control trim material other than standard
- Required standards, certifications and approvals
- Series Number
- Valve Size
- Globe or Angle
- Pressure Class
- Flanged
- Special needs or Installation Requirements

ENGINEERING SPECIFICATIONS

The pressure relief valve shall be a single-seated, line pressure operated, diaphragm actuated, pilot-controlled globe or angle valve. The pressure relief valve shall seal by means of a corrosion-resistant seat and resilient, rectangular seat disc. Maintenance, disassembly and reassembly of all the valve's components shall be made possible on-site and in-line, without the need to remove the valve from the line. The stem of the main valve shall be guided top and bottom by integral bushings. Alignment of the body, bonnet and diaphragm assembly shall be by precision dowel pins. The diaphragm shall not be used as a seating surface, nor shall pistons be used as an operating means. The valve shall be fully trimmed, hydrostatically and operationally tested at the factory and set to a fixed relief pressure. Change of factory preset pressure setting can always be performed in-line following simple IOM instructions, without special tools or system down time. The main valve body and bonnet shall be ductile iron (other materials available upon request). All internal ferrous surfaces shall be coated with epoxy. External surfaces shall be coated with epoxy and fire red paint. The main valve seat ring shall be bronze (other materials available upon request). Elastomers (diaphragms, resilient seats, and O-rings) shall be Buna-N or E.P.D.M. Control pilot shall be bronze or stainless steel. The control line tubing shall be copper (other materials available upon request). Additional coatings and special materials are available upon request. The pressure relief valve shall be a Model 108FC (globe) or 108FCA (angle), UL Listed under QXZQ category and Factory Mutual Approved under 1361 and 1363 categories, sized per NFPA 20 and as manufactured by OCV Fluid Solutions, Tulsa, OK, USA.

OCV companies worldwide reserve the right to make changes without notice including product specification and configuration, content, description(s), dimensions etc. The information herein is subject to change without notice. OCV shall not be held liable for any errors. All rights reserved. © Copyright by OCV.